



SPIRIT FITNESS

A Heritage of Quality | The Spirit of Innovation



GROUP EXERCISE BIKE

OWNER'S MANUAL

PLEASE CAREFULLY READ THIS ENTIRE MANUAL BEFORE
OPERATING YOUR GROUP BIKE!

TABLE OF CONTENTS

Important Safety Instructions.....	3
Guidelines for Safe Operation.....	4
Hardware Assembly Pack.....	5
Adjusting the Bike for a Proper Fit.....	9
How to Use Our Dual Function Pedal.....	10
Basic Operation / Maintenance Guidelines.....	11
Parts list.....	12
Exploded View Drawing.....	15

IMPORTANT SAFETY INSTRUCTIONS

WARNING --READ ALL INSTRUCTIONS BEFORE USING THIS EXERCISE EQUIPMENT

1. Use this equipment only for its intended use as described in this manual. Do not attempt to ride this bike at high pedal speeds until you have ridden the bike for some time and are comfortable riding at slower pedal speeds.
2. The bike is NOT equipped with a freewheel system which means that when the flywheel is in motion, the pedals will be in motion. Do not attempt to stop the unit by applying backward pressure to pedals while they are turning as knee injury may occur. Do not attempt to remove your feet from pedals while they are moving.
3. Wait for flywheel to coast to a stop before dismounting the bike. If you want to stop the flywheel, push down on the brake knob.
4. Serious injury or death may occur from over-training. Consult a medical doctor or qualified fitness instructor to determine an exercise program appropriate for your level of fitness.
5. Do not attempt to turn the pedal cranks by hand. Do not touch any driving mechanism while it is in motion as possible injury could occur.
6. In a home setting, keep children away from the bike when it is not in use. Keep children and pets away from the unit while it is in use.
7. Do not attempt to perform dip movements on handlebars.
8. Never drop or insert any object into any opening of the bike.
9. Only use the bike on a stable, level floor.
10. Follow instructions for safe use of the equipment including proper seat position, handlebar position, and use of foot positioning system of pedals. Do not attempt to pull up handlebar post and seat post over the 'MAX.' graduation.
11. For safe operation, allow for at least 1 foot (30cm) of free space to either side of the unit and 2 feet (60cm) of free space to the rear of the unit.
12. Regularly examine the bike for damage and wear. Inoperable components should be replaced immediately or the equipment should not be used until it is repaired.

Failure to follow all guidelines may compromise the effectiveness of the exercise experience, expose yourself (and possibly others) to injury, and reduce the longevity of the equipment.

SAVE THESE INSTRUCTIONS - THINK SAFETY!

NEVER expose the bike to rain or moisture. This product is **NOT** designed for use outdoors, near a pool or spa, or in any other high humidity environment. Maximum environmental ratings are 40-120 degrees Fahrenheit, 95% humidity non-condensing (no water droplets forming on surfaces).

GUIDELINES FOR SAFE OPERATION

WARNING!

AS THE OWNER OF THIS EXERCISE EQUIPMENT, YOU SHOULD INSIST THAT ALL USERS FOLLOW THE SAME GUIDELINES: YOU SHOULD MAKE THIS MANUAL AVAILABLE TO ALL USERS.

1. Obtain a complete physical examination from your medical doctor and enlist a health/fitness professional's aid in developing an exercise program suitable for your current health status.
2. When working out for the first time, start out slowly for a minimum of five minutes. After your muscles are warmed up, gradually increase the pedaling rate zone.
3. The speed and duration of your exercise program should always be subject to how you feel. Never permit peer pressure to exceed your personal judgment while exercising.
4. Overweight or severely de-conditioned individuals should be particularly cautious when using the equipment for the first time. Even though such individuals may not have histories of serious physical problems, they may perceive the exercise to be far less intense than it really is, resulting in the possibility of overexertion or injury.
5. Proper installation and regular maintenance are required to ensure user's safety. Maintenance is the sole responsibility of the owner.

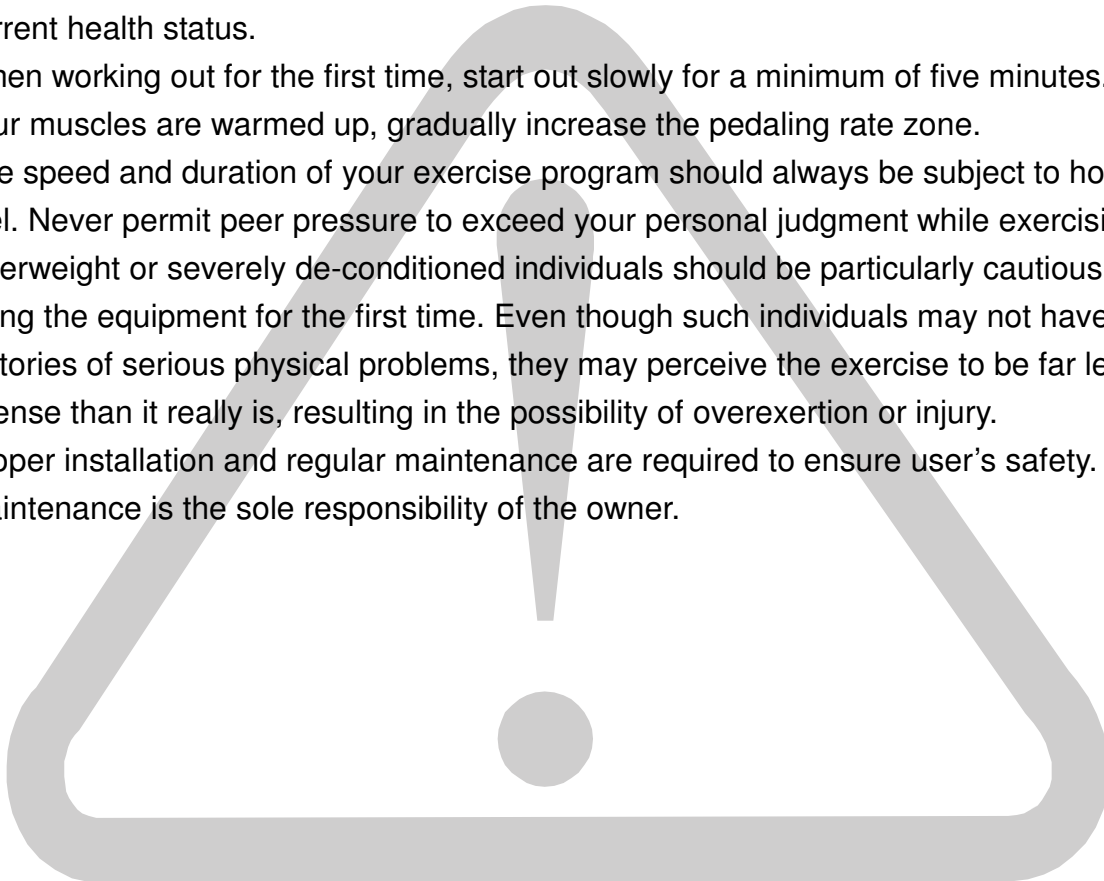

ASSEMBLY INSTRUCTIONS

Pre-Assembly

1. Cut the straps, then pull the staples in the outer cardboard away from the layer beneath; lift the box over the unit and unpack.
2. Locate the hardware package. The hardware is separated into three steps. Remove the tools first. Remove the hardware for each step as needed to avoid confusion. The numbers in the instructions that are in parenthesis (#) are the item number from the assembly drawing for reference.

ASSEMBLY TOOLS

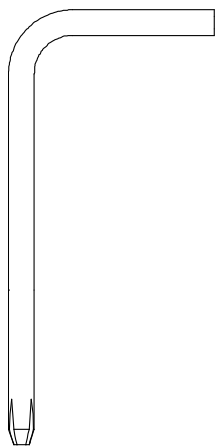

#87. Combination M5 Allen Wrench
& Phillips Head Screw Driver (1pc)

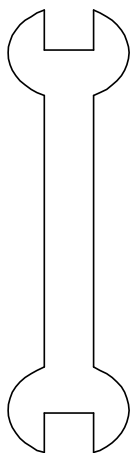

#86. 14/15mm Wrench (1pc)

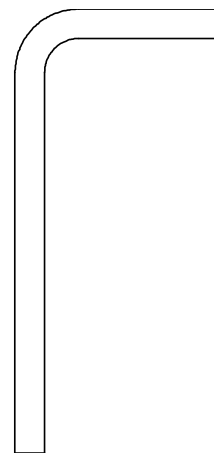

#85. 6mm L Allen Wrench (1pc)

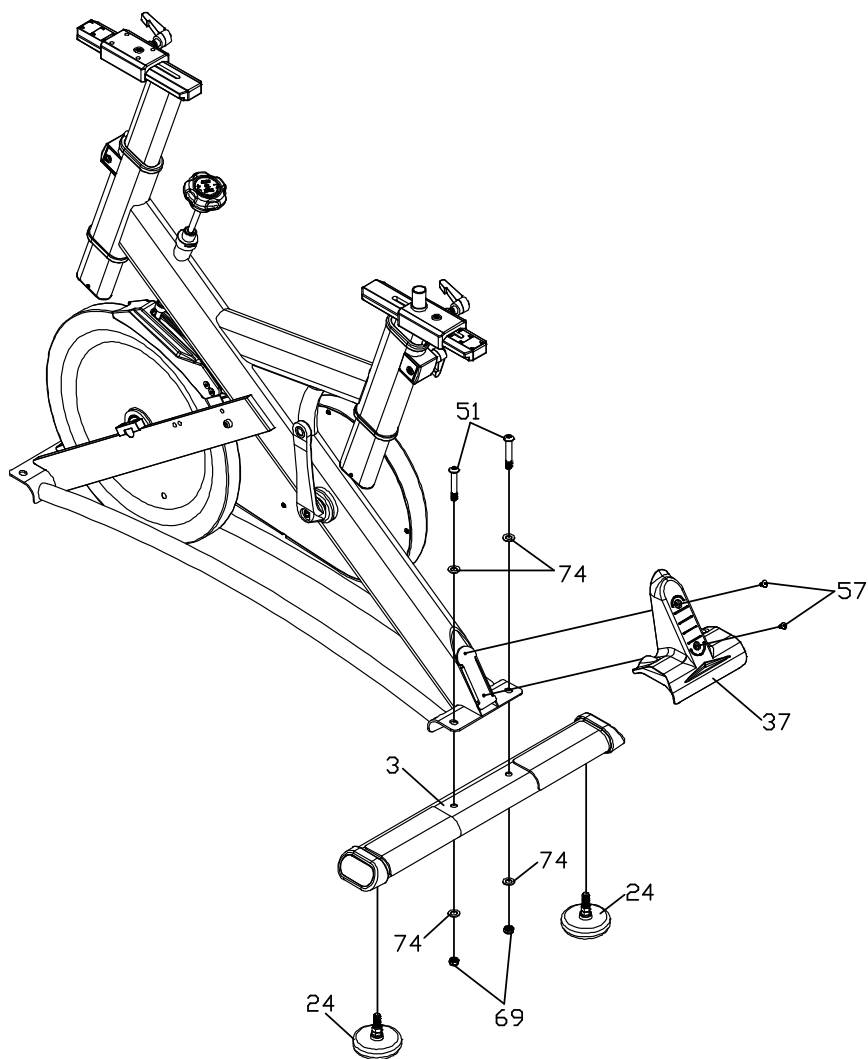

1 Rear Stabilizer Assembly

First, screw in two Leveling Glides (24) onto the Rear Stabilizer (3) and place the Rear Stabilizer (3) under the frame attaching plates at the rear end of the mainframe. Align the screw holes and insert two 3/8" x 2-1/4" Button Head Socket Bolts (51) with 3/8" x 19 x 1.5T Flat Washers (74) through the holes and tighten with 3/8" x 19 x 1.5T Flat Washers (74) and 3/8" - 11T Nyloc Nuts (69) by using 6m/m L Allen Wrench (85) and 14.15m/m Wrench (86). Cover the rear end of the mainframe with Rear Step Cover (37) to be tightened with M5 x 10m/m Phillips Head Screws (57) by using Combination M5 Allen Wrench & Phillips Head Screw Driver (87).

HARDWARE

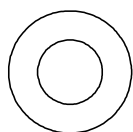

#74. 3/8" x 19 x 1.5T Flat Washer (4pcs)



#69. 3/8" Nyloc Nut (2pcs)



#57. M5 x 10m/m Phillips Head Screw (2pcs)

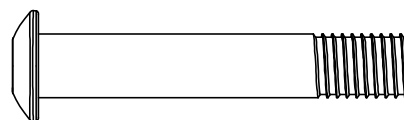

#51. 3/8" x 2-1/4" Button Head Socket Bolt (2pcs)

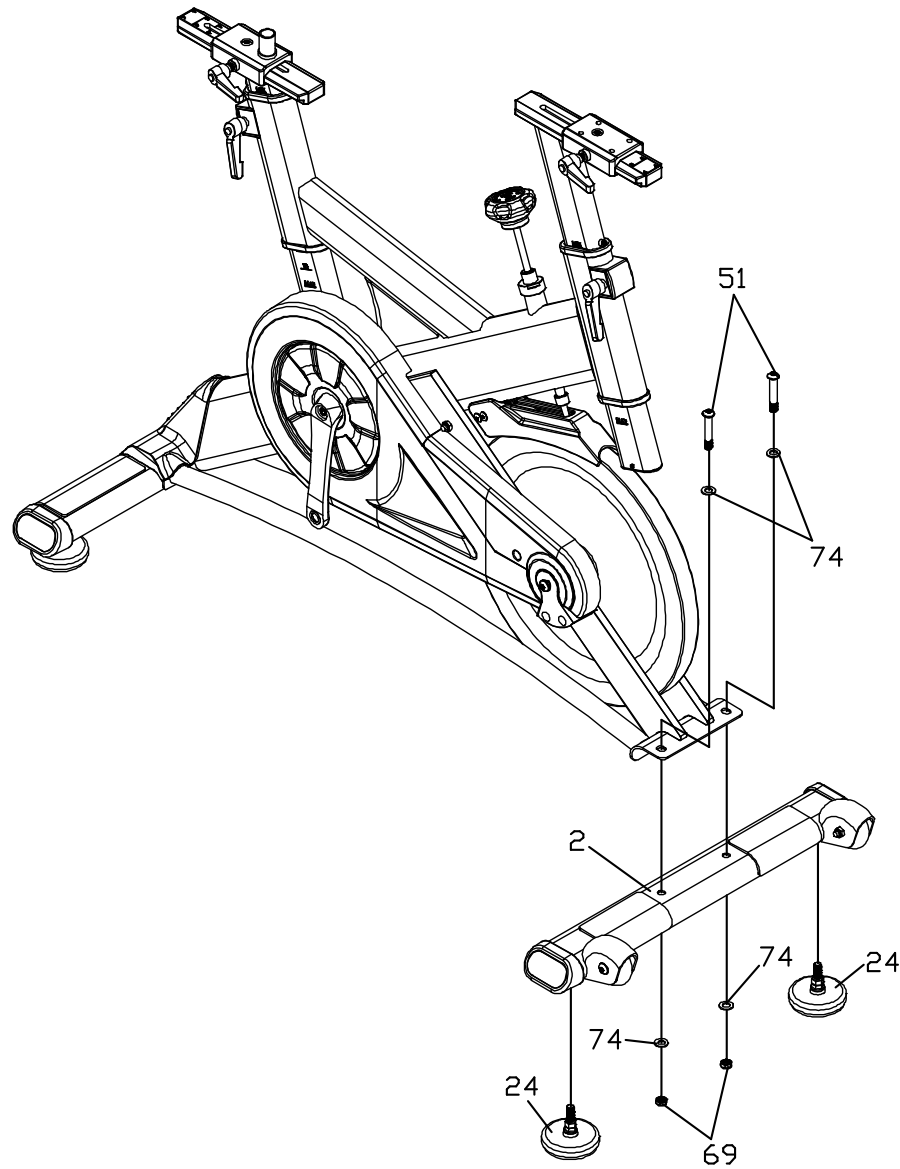

2 Front Stabilizer Assembly

Screw in two Leveling Glides (24) onto the Front Stabilizer (2) and Place the Front Stabilizer (2) under the frame attaching plates at the front end of the mainframe. Align the screw holes and insert two 3/8" x 2-1/4" Button Head Socket Bolts (51) with 3/8" x 19 x 1.5T Flat Washers (74) through the holes and tighten with 3/8" x 19 x 1.5T Flat Washers (74) and 3/8" - 11T Nyloc Nuts (69) by using 6m/m L Allen Wrench (85) and 14.15m/m Wrench (86).

HARDWARE

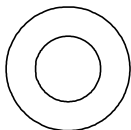

#74. 3/8" x 19 x 1.5T
Flat Washer (4pcs)



#69. 3/8" Nyloc Nut
(2pcs)

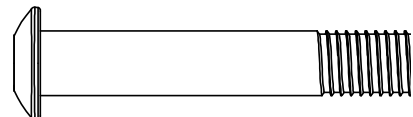

#51. 3/8" x 2-1/4"
Button Head Socket Bolt
(2pcs)

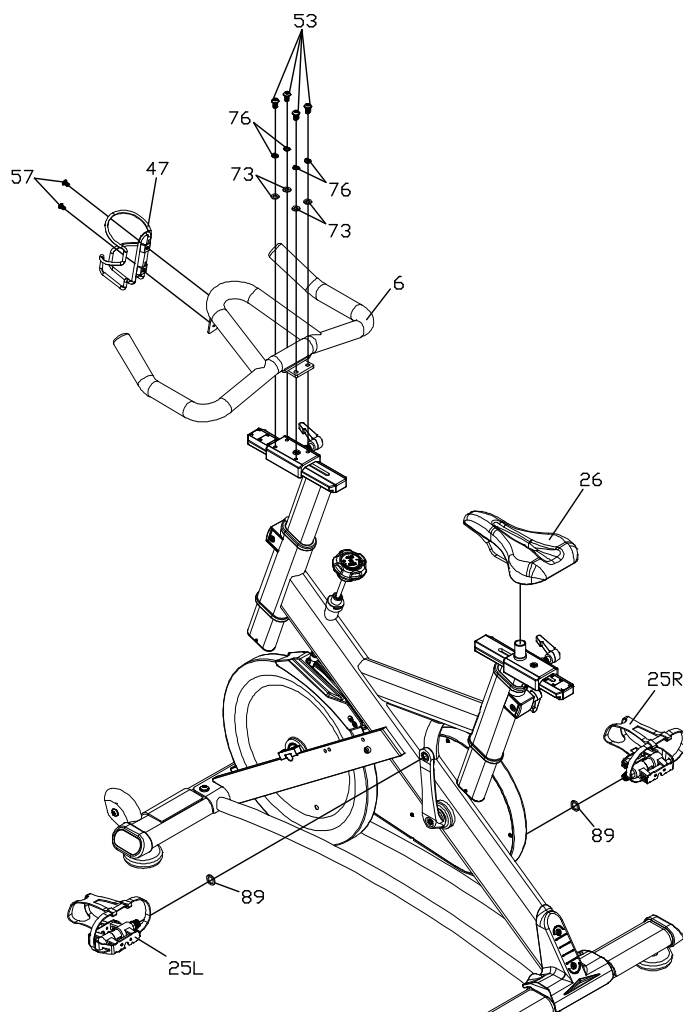

3 Handlebar, Saddle and Pedals Assembly

Place the Handle Bar (6) on the top end of the Handlebar Post and secure with M8 × 15L Button Head Socket Bolts (53), Ø8 × 1.5T (5/16" × 1.5T) Split Washers (76) and 5/16" × 16 × 1.5T Flat Washers (73) by using Combination M5 Allen Wrench & Phillips Head Screw Driver (87). Use the same screw driver (87) to secure the Drink Bottle Holder with M5 × 10m/m Phillips Head Screws (57). Finally, use 14.15m/m Wrench (86) to secure the Saddle (26). Apply Ø14 × 20 × 2.0T Flat Washers (89) on Pedals (25L · 25R) and again use 14.15m/m Wrench (86) to secure.

Note: the left pedal uses a left hand thread, so you will tighten by threading it in counterclockwise.

HARDWARE

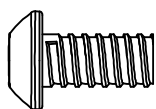

#53. M8 × 15mm
Button Head Socket
Bolt (4pcs)



#76. 5/16" × 1.5T
Split Washer
(4pcs)

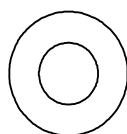

#73. 5/16" × 16 × 1.5T
Flat Washer
(4pcs)



#57. M5 × 10m/m
Phillips Head Screw
(2pcs)

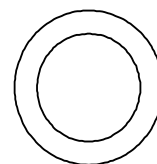

#89. Ø14 × 20 × 2.0T
Flat Washer
(2pcs)

ADJUSTING THE BIKE FOR A PROPER FIT

Take some time to learn how to properly adjust the bike to your body; it will make your workouts more pleasant and a safer experience too. Riding the bike when it is incorrectly adjusted can result in discomfort and increase your risk of injury.

Adjustment of Seat Position:

Seat Height Adjustment

1. Standing next to the bike, adjust seat until it is about hip height.
2. Rotate crank arms until the pedals are in the vertical position: 12 and 6 o'clock.
3. Place your foot in toe cage of pedal closest to the floor and mount the bike. Ensure that the ball of your foot is over the center of pedal. Your leg should be slightly bent at the knee, about 5 degrees.
4. If your leg is too straight or your foot cannot touch pedal you will need to lower seat height. If your leg is bent too much you will need to raise seat height.
5. Dismount the bike. Loosen the quick release lever on seat post and adjust up or down as necessary.
6. When seat is in the desired position, tighten the quick release to secure the seat post.
7. Note the final position mark on the seat post for future reference.

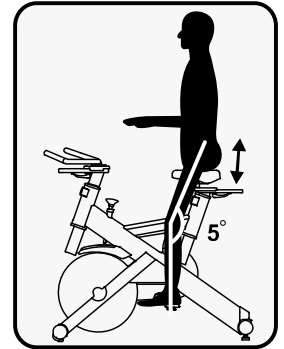

Seat Forward/Aft Adjustment

1. Sit on bike with crank arms in the 3 and 9 o'clock positions. For road bike training, a proper forward/aft position of the seat is achieved when small bump at the top of the shin is above pedal axle.
2. Dismount the bike. Loosen the quick release under the seat and slide the seat forward or backward as desired; then tighten the quick release.

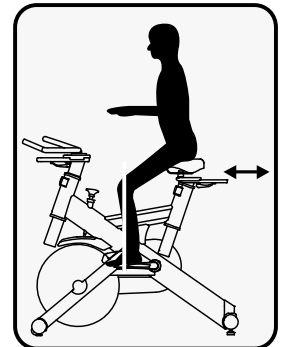

Handlebar Adjustment:

Handlebar Height Adjustment

1. The Handlebar height is a matter of preference. Start with a handlebar height that is the same as the seat's height. Adjusting the handlebar higher will give the rider a more upright position; lower will result in a more crouched position.
2. Raise or lower the handlebar by loosening quick release on handlebar post and adjust by sliding the handlebar mount up or down as desired. Then tighten the quick release to secure the handlebar post. Note the final position mark on handlebar post for future reference.

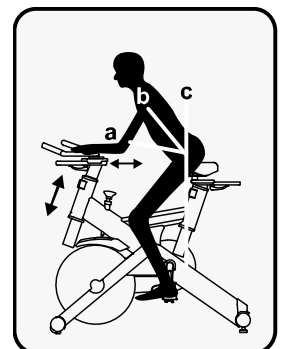

Adjustment of Handlebar's Forward/Aft Position

1. Loosen the quick release under the handlebar and slide the handlebar forward or backward as desired. Suitable forward/aft position should allow the rider to comfortably grasp the handlebar with a slight bend at the elbow.
2. Tighten the quick release to secure the handlebar assembly.

HOW TO USE OUR DUAL FUNCTION PEDAL

Attaching Cleats to Your Shoes

If you have questions it is recommended that you consult a bicycle dealer for assistance, and also refer to your shoe manufacturer's instructions.

When fixing the cleat the lateral center line should be under the center of the ball of the foot. Adjust forward and backward via the slots in the shoe sole. Adjust laterally via play between cleat washer and cleat. Tighten cleats very firmly. Cleat position can be fine-tuned, according to personal preference, after trial use. It may take time to find your optimum cleat set-up.

Toe Clips

All standard toe clips can be attached to the pedals. Use fixing hardware and installation instructions supplied with toe clips and ensure the attachment screws are firmly tightened before use.

To Use Pedals

Engage cleated shoes in pedals by placing cleat between bindings while pushing down.

Disengage by twisting heel outwards away from exercise bike.

Binding tension is adjustable and should be set so that cleat and shoe do not disengage when pedaling. Use an Allen key to turn tension adjusting screws, clockwise to increase binding tension, counterclockwise to decrease binding tension.

Use the opposite side of the pedal from the clip-in side when wearing regular sports training shoes. The regular side can be used with or without toe clips.

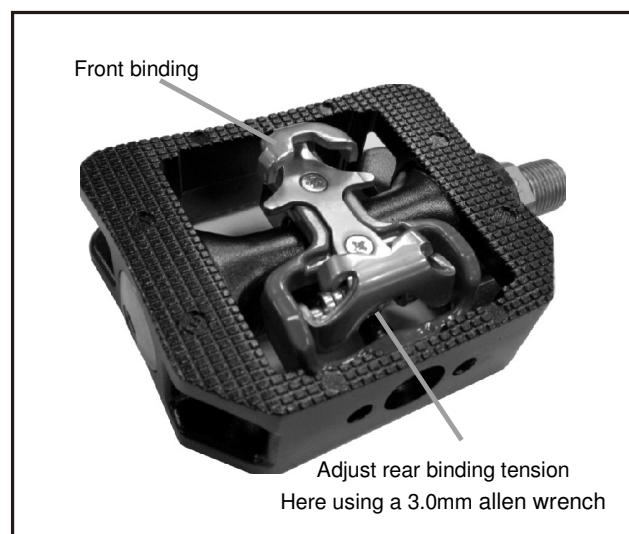
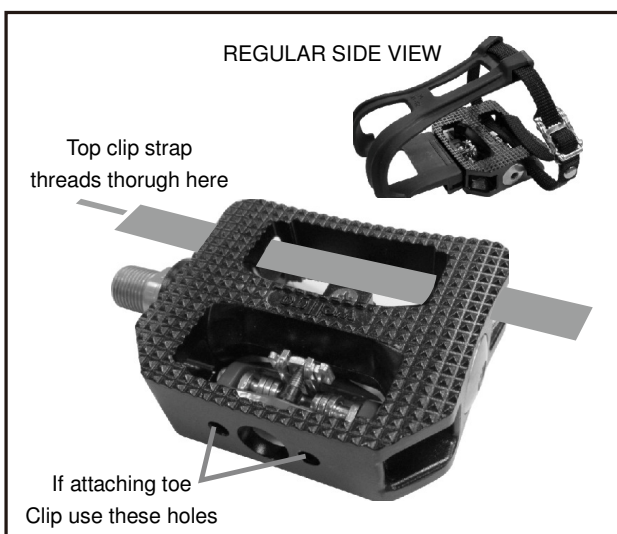

BASIC OPERATION

Now that you have established a proper riding position, take a few minutes to ride the bike and determine that your position is comfortable. Start pedaling at a slow pace with your toes and knees pointed directly forward. Hold the handlebar lightly and in a position that allows your shoulders and upper body to relax. Pedal easily, at a low resistance until you feel confident that you could ride in that position for the duration of your workout.

WARNING!

IF AT ANY TIME DURING YOUR WORKOUT, YOU FEEL CHEST PAIN, EXPERIENCE SEVERE MUSCULAR DISCOMFORT, FEEL FAINT, OR ARE SHORT OF BREATH, STOP EXERCISING AT ONCE. IF THE CONDITION PERSISTS, YOU SHOULD CONSULT YOUR MEDICAL DOCTOR IMMEDIATELY.

1. Pedaling resistance is controlled by the tension knob. Resistance can be changed at any time by turning tension knob: clock-wise for more resistance; counterclockwise for less resistance.
2. To apply the brake, press down on the tension knob.
3. Before dismounting, apply the brake to stop flywheel, or increase resistance and let flywheel come to a stop.

MAINTENANCE GUIDELINES

MAINTENANCE SCHEDULE

PART	RECOMMENDED ACTION	FREQUENCY	CLEANER	LUBRICANT
Pedals	Ensure that pedals are tight in crank arms; that all screws on pedals are tight; and that the pedal straps are not frayed	Before each use	N/A	N/A
Frame	Wipe down by using a soft damp clean cloth	Daily	Water	N/A
Flywheel	Wipe down by using a soft damp clean cloth.	Weekly	Water	N/A
Brake Pad	Check for wear.	Monthly	N/A	N/A

1. Do not service internal parts of pedals. If they are found to be worn internally, we recommend replacing the pedal.
2. Use of lubricants or cleaning solutions other than those so specified will result in diminished performance and a shorter life span for that part.

PARTS LIST

No.	Description	Qty
1	Mainframe Assembly	1
2	Front Stabilizer	1
3	Rear Stabilizer	1
4	Handlebar Mast Tube	1
5	Seat Mast Tube	1
6	Handle Bar	1
7	Seat Mount Slide	1
8	Handle Bar Mount Slide	1
9	Felt Pad Mounting Arm	1
10	Felt Pad	1
11	Brake Push Rod Bushing	1
12	Brake Push Rod Assembly Cap	1
13	Brake Return Spring	1
14	Resistance Knob	1
15	Idler Bearing Axle	1
16	Idler Axle Bolt & Adjustment Slider	1
17	Belt Guard Cover, Rear	1
18	Double-D Flat Washer	1
19	1.0 × 8 × 11 × 25m/m_Constrict Spring	2
20	Lateral Wedge, Seat Handle Bar Slide	2
21	M10 × 17L_Seat/Handlebar Adj. Locking Lever	2
22	M8 × 42.5L_Seat/Handlebar Mast Adj. Locking Lever	2
23	Transport Wheel	2
24	Leveling Glide	4
25	Pedal (Left and Right)	1
26	Saddle	1
27	Flywheel	1
28	Flywheel Axle Mount, Right Side	1
29	Flywheel Axle	1
30	Flywheel Axle Hold-Down, Left Side	1
31	6203_Bearing	2
32	Poly-V Drive Belt	1
33	Drive Pulley	1
34	Crank Arm (L)	1
35	Crank Arm (R)	1
36	Bottom Bracket Cartridge	1
36-1	M12_Crank Arm Retaining Bolt	2
37	Rear Step Cover	1
38	Right Crank Arm Cover	1

No.	Description	Qty
39	Tube Slide Bushing	2
40	Tube Slide Insert	2
41	Flywheel Fender	1
42	Belt Guard Cover	1
43	Oval End Cap with SPIRIT logo	4
45	V-Block, Right(6061-T6)	1
46	V-Block, Left(6061-T6)	1
47	Water Bottle Cage	1
48	6004_Bearing	1
49	Flywheel Bearing, Needle	1
50	5/16" × 42m/m_Button Head Socket Bolt	2
51	3/8" × 2-1/4"_Button Head Socket Bolt	4
52	M8 × 10L_Button Head Socket Bolt	2
53	M8 × 15L_Button Head Socket Bolt	4
54	M6 × 10L_Button Head Socket Bolt	1
55	M10 × 15L_Button Head Socket Bolt	1
56	M4 × 8L_Phillips Head Screw	2
57	M5 × 10m/m_Phillips Head Screw	11
58	M6 × 15m/m_Phillips Head Screw	4
59	M5 × 12m/m_Tapping Screw	2
61	3.5 × 12m/m_Sheet Metal Screw	3
62	5 × 16m/m_Sheet Metal Screw	4
63	1/4" × 3"_Hex Head Bolt	1
64	M6 × 12L_Socket Head Cap Bolt	2
65	M6 × 20L_Socket Head Cap Bolt	2
66	M3 × 6m/m_Socket Head Cap Bolt	6
67	1/4" - 5.5T_Nyloc Nut	1
68	5/16"- 7T_Nyloc Nut	2
69	3/8" - 11T_Nyloc Nut	4
70	M10 × 1.25 × 15L_Socket Head Cap Bolt	4
71	Ø4 × 14 × 1.0T_Flat Washer	2
72	1/4" × 13 × 1.0T_Flat Washer	1
73	5/16" × 16 × 1.5T_Flat Washer	4
74	3/8" × 19 × 1.5T_Flat Washer	8
75	Ø8.7 × Ø20 × 1.5T_Flat Washer	1
76	Ø8 × 1.5T (5/16" × 1.5T)_Split Washer	4
77	M10 × 16.5 × 2T × 4H_Split Washer	5
78	Ø20_C Ring	2
79	Ø17_C Ring	1
80	Ø16.7 × 2.5T_Star Washer	1

No.	Description	Qty
81	Ø2 × 12m/m_Fixing Pin	1
82	M6 × 1.0-20L_Slotted Set Screw	2
83	Sleeve, Brake Push Rod	1
84	Return Spring, Felt Pad	1
85	6m/m_L Allen Wrench	1
86	14.15m/m_Wrench	1
87	Combination M5 Allen Wrench & Phillips Head Screw Driver	1
88	M5 × 15m/m_Phillips Head Screw	4
89	Ø14 × 20 × 2.0T_Flat Washer	2
90	160 × 80mm × 1T_Rubber Pad	2
91	120 × 80mm × 1T_Rubber Pad	2
92	Magnet	1
93	Hollow Plug	2
94	M8 × 70m/m_Socket Head Cap Bolt	1
95	M8 × 7T_Nyloc Nut	1
96	M6 × 15L_Button Head Socket Bolt	2
97	Aluminum Locking V-Blocks(6061-T6)	1
98	Aluminum Locking V-Blocks(6061-T6)(M8)	1
99	Ø8 × 16 × 1.0T_Flat Washer	2
100	Ø3/8" × 22 × 1.5T_Flat Washer	1
101	Ø40_C Ring	1
102	Ø52 × Ø40 × 28m/m_Bushing	1
109	Console Bracket (Optional)	1
110	Console Assembly (Optional)	1

Exploded View Drawing

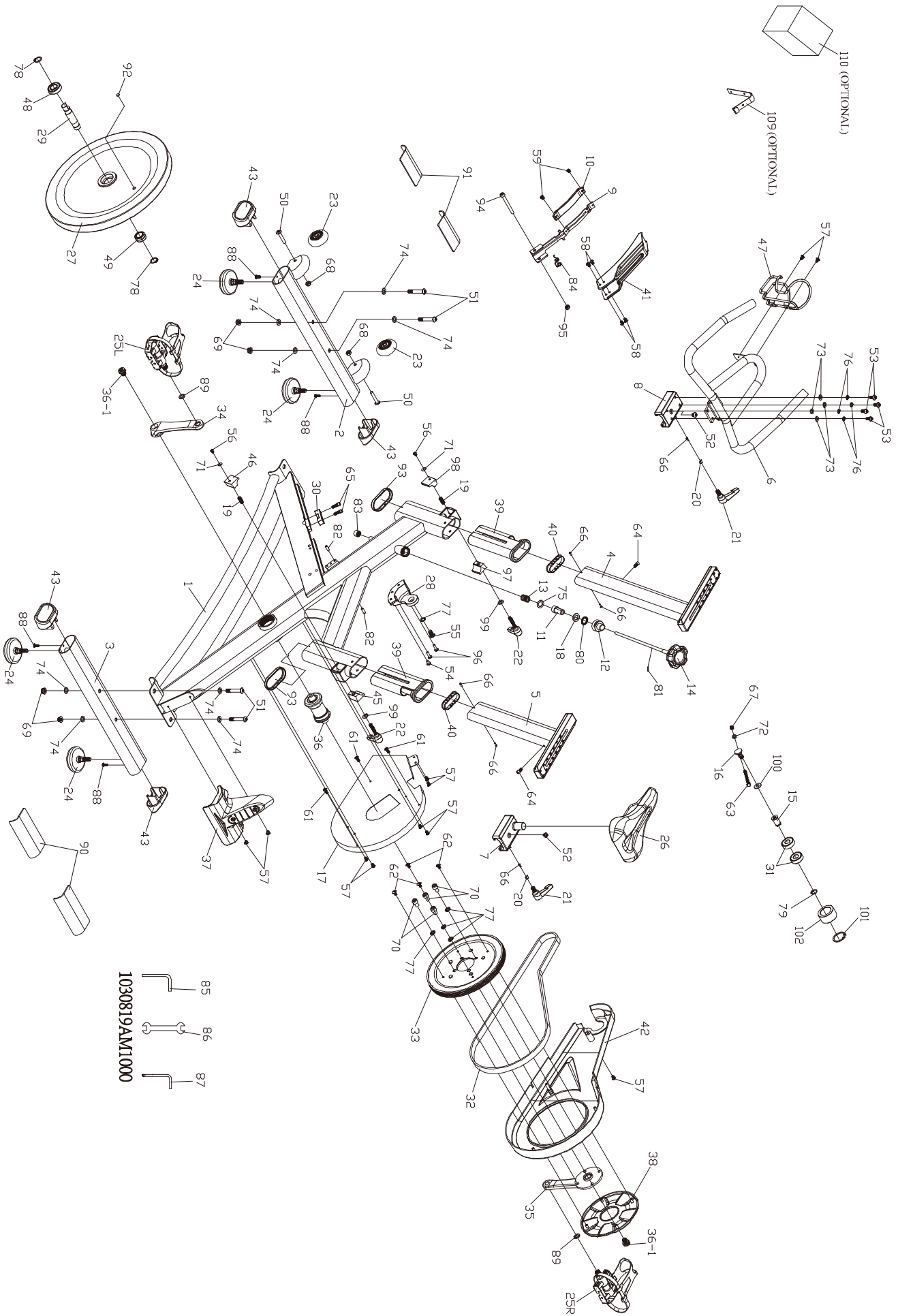

1030819AM1000

85

86

87