

FLP

Body-Solid®

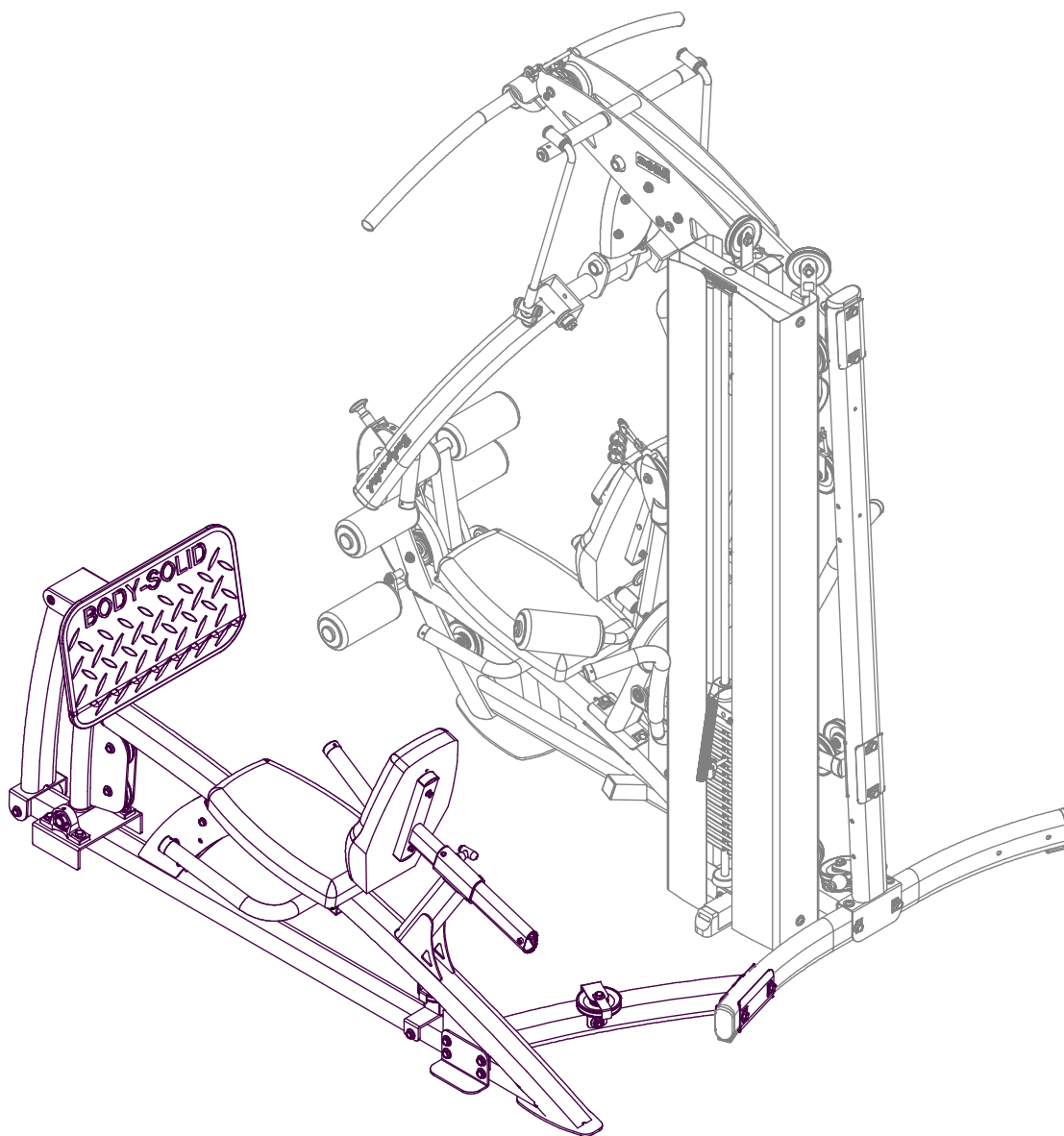

Assembly

Instructions

OWNER'S

&

MANUAL

STEP

1

Be careful to assemble all components in the sequence they are presented.

NOTE:

Finger tighten all hardware in this step. Do Not wrench tighten until end of step 6.

- A. Connect Mainframe (A) to Linkage Frame (L) and Plate (J) by using:
Four A1 (M10x130 hex dbolt)
Eight C1 (M10 washer)
Four B1 (M10 nylon lock nut)

- B. Connect gym to Linkage Frame (L) and Plate (K) by using:
Two A9 (M10x80 hex head bolt)
Four C1 (M10 washer)
Two B1 (M10 nylon lock nut)

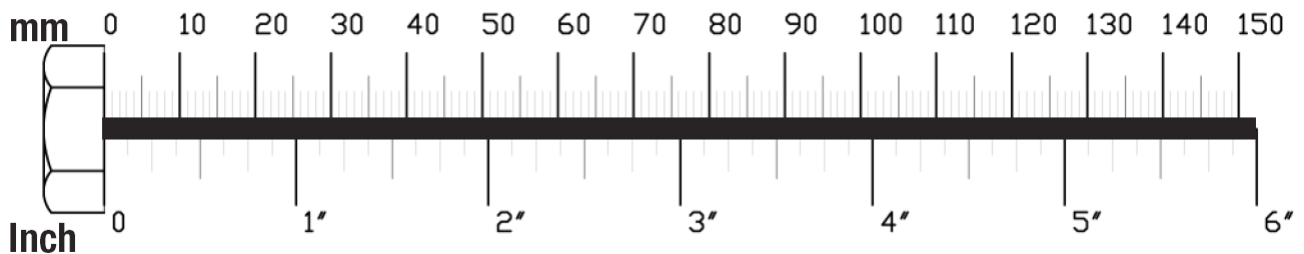

STEP
1

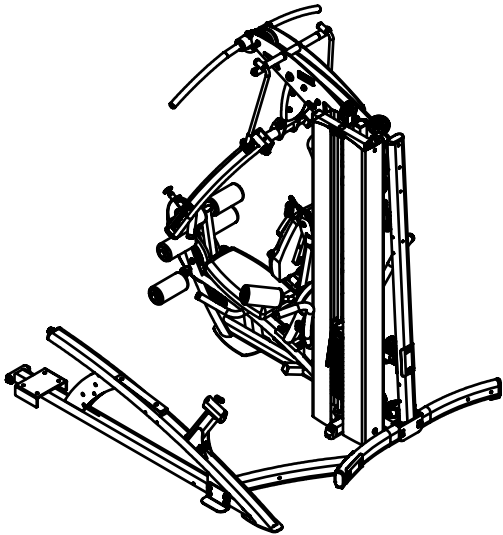

Above shows STEP 1 assembled and completed

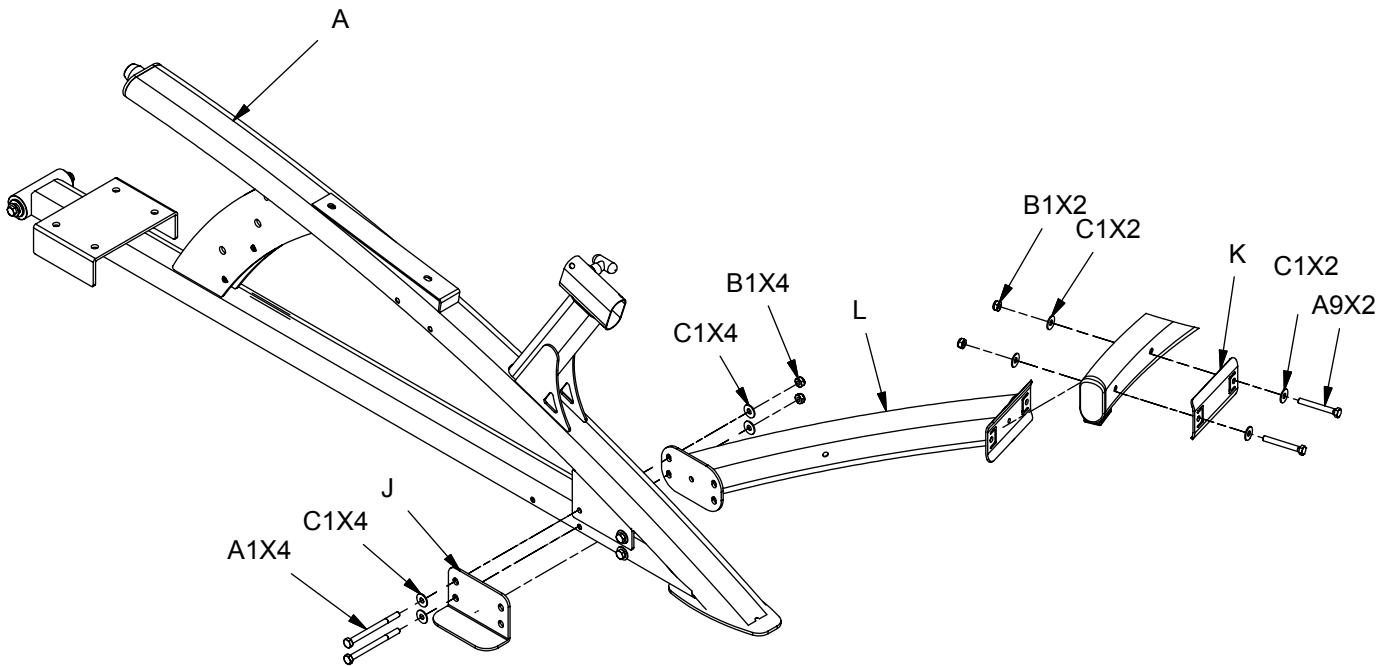

STEP**2**

**Be careful to assemble all components
in the sequence they are presented.**

NOTE:

Finger tighten all hardware in this step. Do Not wrench tighten until end of step 6.

- A. Connect Upright Frame (E) to Mainframe (A) using:
Four A13 (M12x40 hex head bolt)
Four C2 (M12 washer)
Four B2 (M12 nylon lock nut)

- B. Slide Shaft (D11) through Leg Frame (D) and Mainframe (A) and tighten using:
Two A14 (M10x20 hex head bolt)
Two C1 (M10 washer)

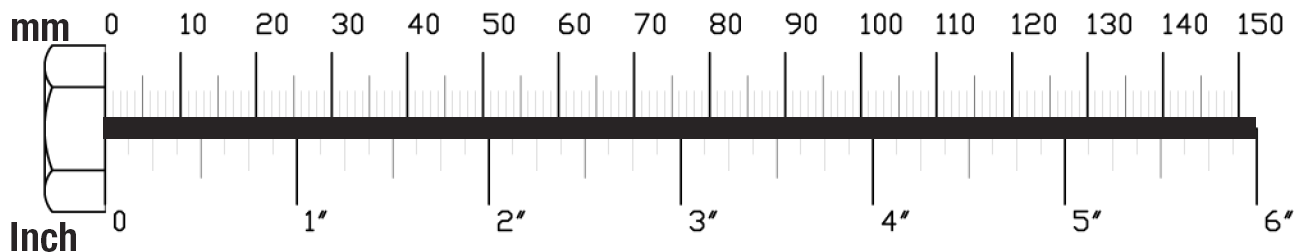

STEP
2

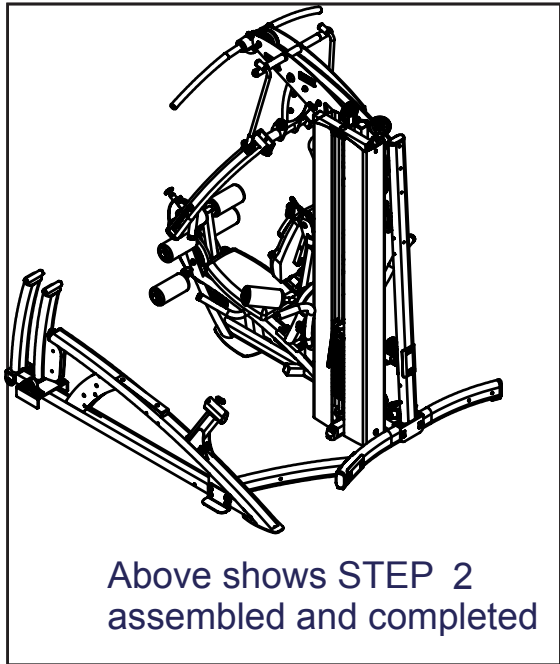

Above shows STEP 2 assembled and completed

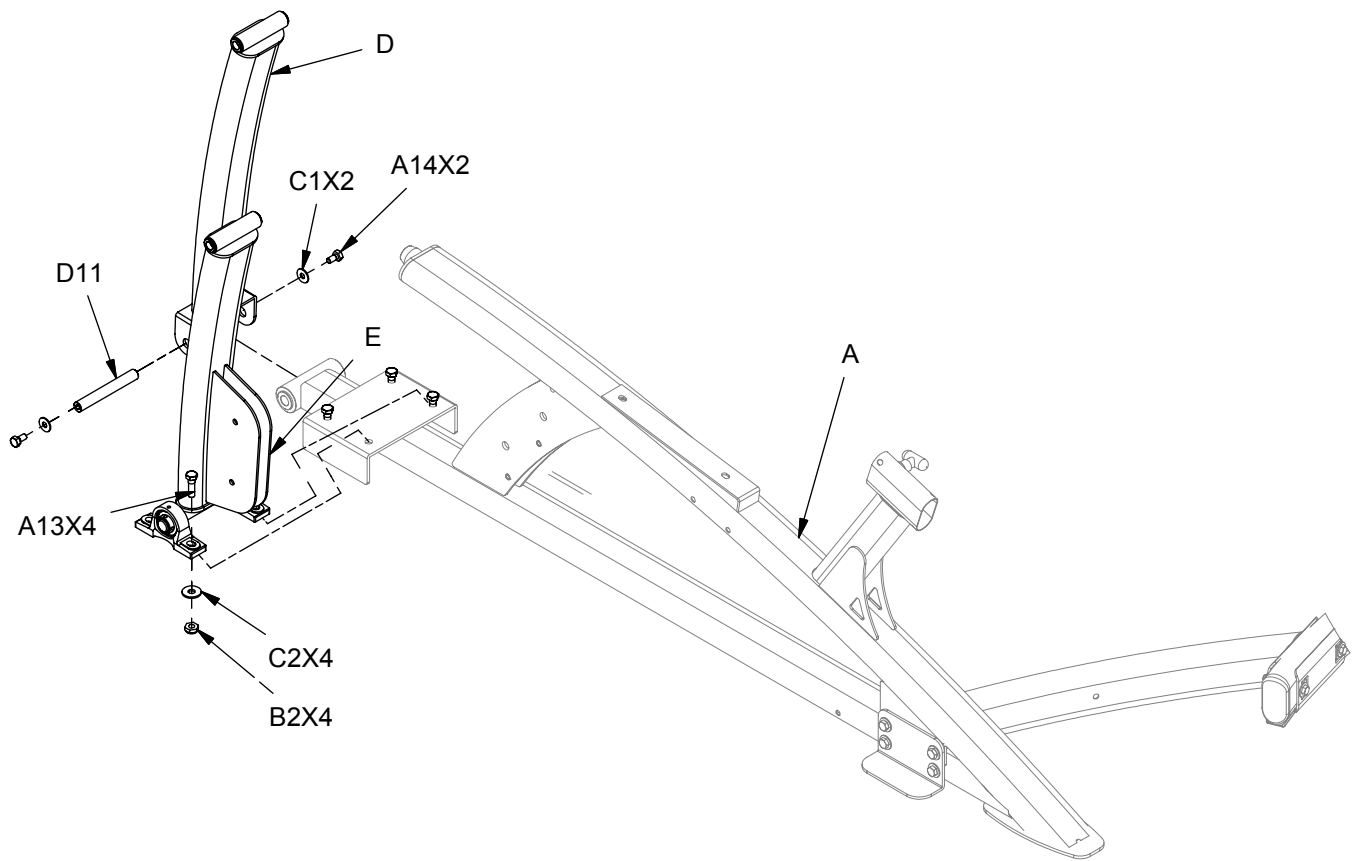

STEP**3****Be careful to assemble all components
in the sequence they are presented.****NOTE:**

Finger tighten all hardware in this step. Do Not wrench tighten until end of step 6.

- A. Install Connector Frame (E) to Leg Frame (D) and Upright Frame (E) by using:
Two D12 (M8 Shaft)
Four A15 (M8x20 allen head bolt)
Four C3 (M8 washer)

- B. Insert End Caps (D4) to Foot Plate (G).

- C. Connect Foot Plate (G) to Connector Frame (C) using:
Two A2 (M12x80 hex head bolt)
Four C2 (M12 washer)
Two B2 (M12 nylon lock nut)

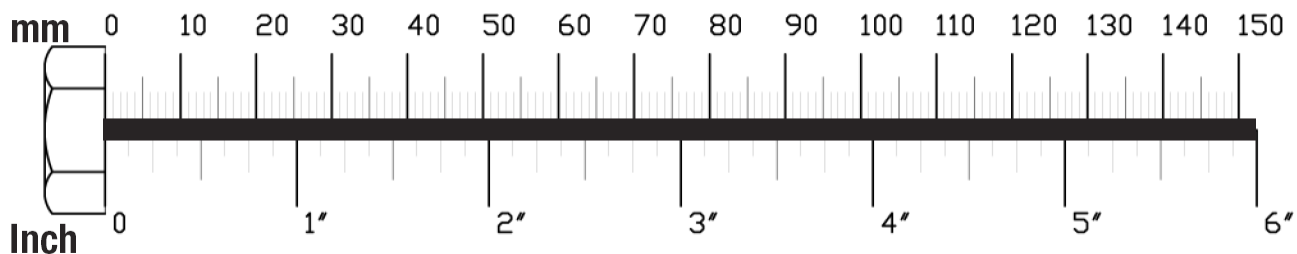

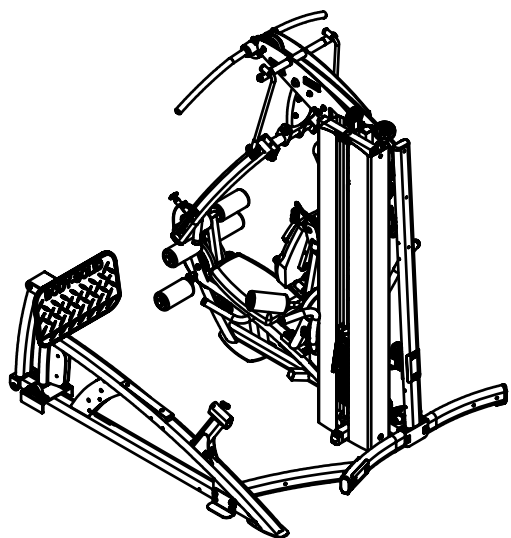

Above shows STEP 3 assembled and completed

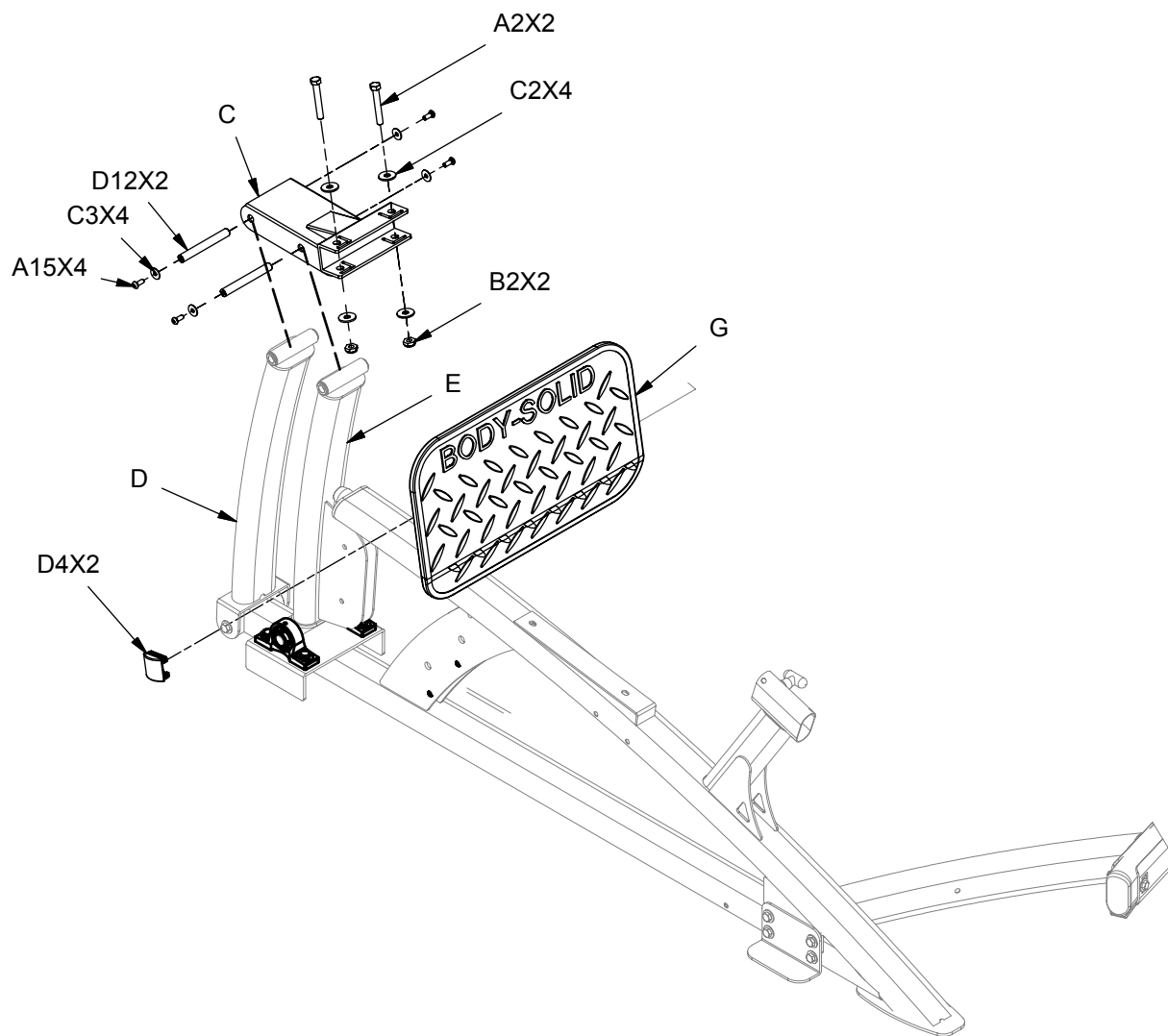

STEP**4****Be careful to assemble all components in the sequence they are presented.****NOTE:**

Finger tighten all hardware in this step. Do Not wrench tighten until end of step 6.

- A. Install Pulleys (D1-A) and (D1-B) into Mainframe (A) by using:
Two A10 (M10x60 hex head bolt)
Two D5 (steel bushing)
Two B1 (M10 nylon lock nut)
- B. Install Pulleys (D1-C) and (D1-D) into Connector Frame (E) using:
Two A6 (M10x50 hex head bolt)
Four C1 (M10 washer)
Two B1 (M10 nylon lock nut)
- C. Attach Handle Bar (B) to Mainframe (A) using:
Two A1 (M10x130 hex head bolt)
Four C1 (M10 washer)
Two B1 (M10 nylon lock nut)
- D. Insert End Cap (D8) into Pulley Frame (H). Attach Pulley Frame (H) to Mainframe (A) using:
One A1 (M10x130 hex head bolt)
Two C1 (M10 washer)
One B1 (M10 nylon lock nut)
- E. Connect Pulley (D1-E) to Pulley Frame (H) using:
One Q ("L" pulley cable plate)
One C1 (M10 washer)
One B1 (M10 nylon lock nut)
- F. Attach Pulley Mount (O) to Linkage Frame (L) using:
One A5 (M10x75 hex head bolt)
Two C1 (M10 washer)
One B1 (M10 nylon lock nut)
- G. Assemble Pulley (D1-F) to Pulley Mount (O) using:
One Q ("L" pulley cable plate)
One A4 (M10x45 hex head bolt)
Two C1 (M10 washer)
One B1 (M10 nylon lock nut)

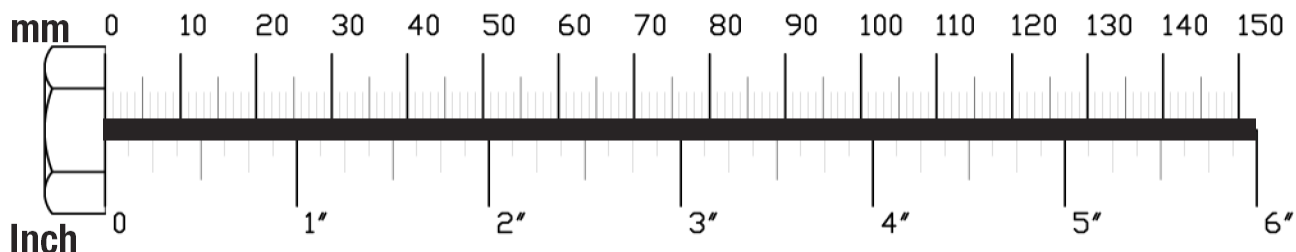

STEP
4

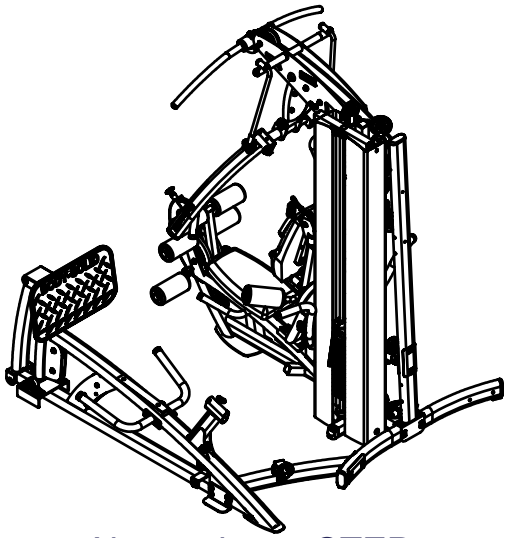

Above shows STEP 4 assembled and completed

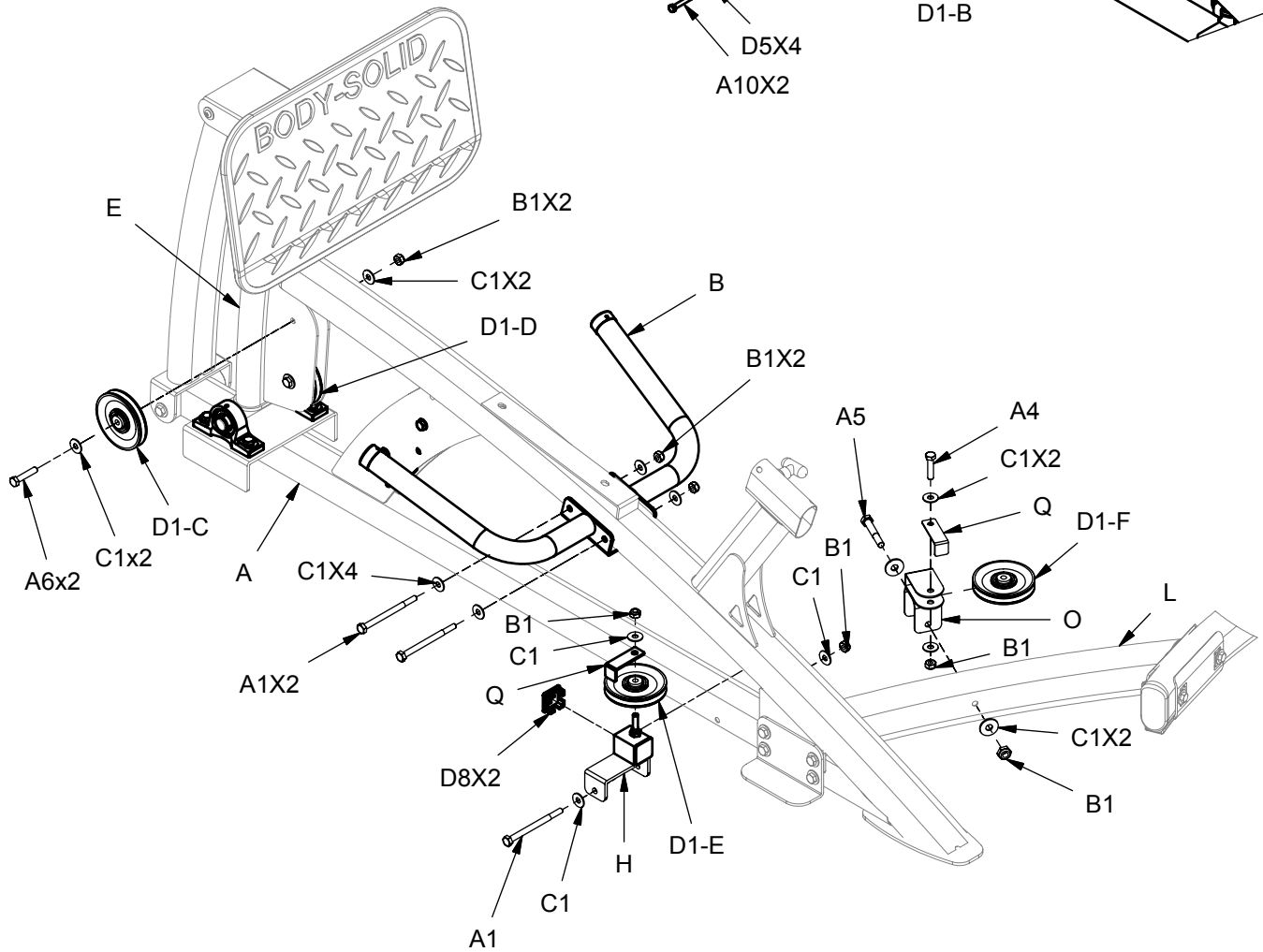
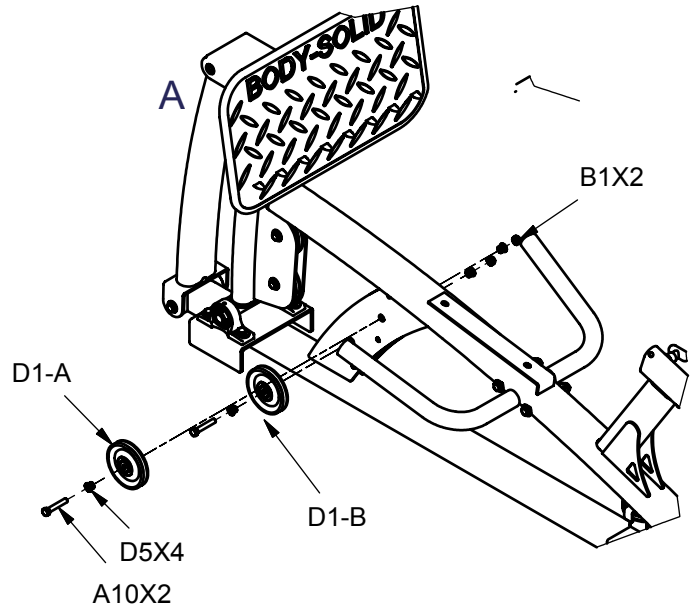

STEP**5****Be careful to assemble all components in the sequence they are presented.****NOTE:**

Finger tighten all hardware in this step. Do Not wrench tighten until end of step 6.

- A. Connect Seat Pad (M) to Mainframe (A) by using:
One A11 (M8x80 hex head bolt)
One A7 (M8x100 hex head bolt)
Two C4 (M8 spring lock washer)
Two C3 (M8 washer)
- B. Insert End Caps (D2) to ends of Back Pad support (F).
- C. Connect Plastic Sleeve (D3) to Mainframe (A) as shown in the diagram. Insert End Cap into the end of Back Pad Support (F).
- D. Slide Back Pad Support (F) through Mainframe (A) as shown in the diagram.
- E. Connect Back Pad (N) to Back Pad Support (F) by using:
Two A8 (M8x50 hex head bolt)
Two C4 (M8 spring lock washer)
Two C3 (M8 washer)
- F. Slide Pad Wrap onto Back Pad (N).

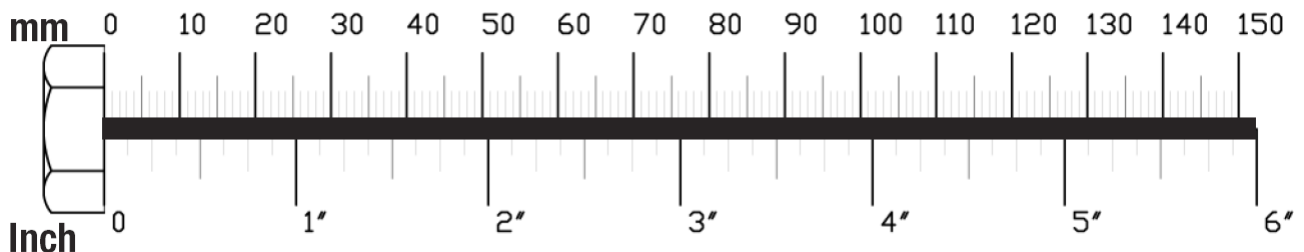

STEP
5

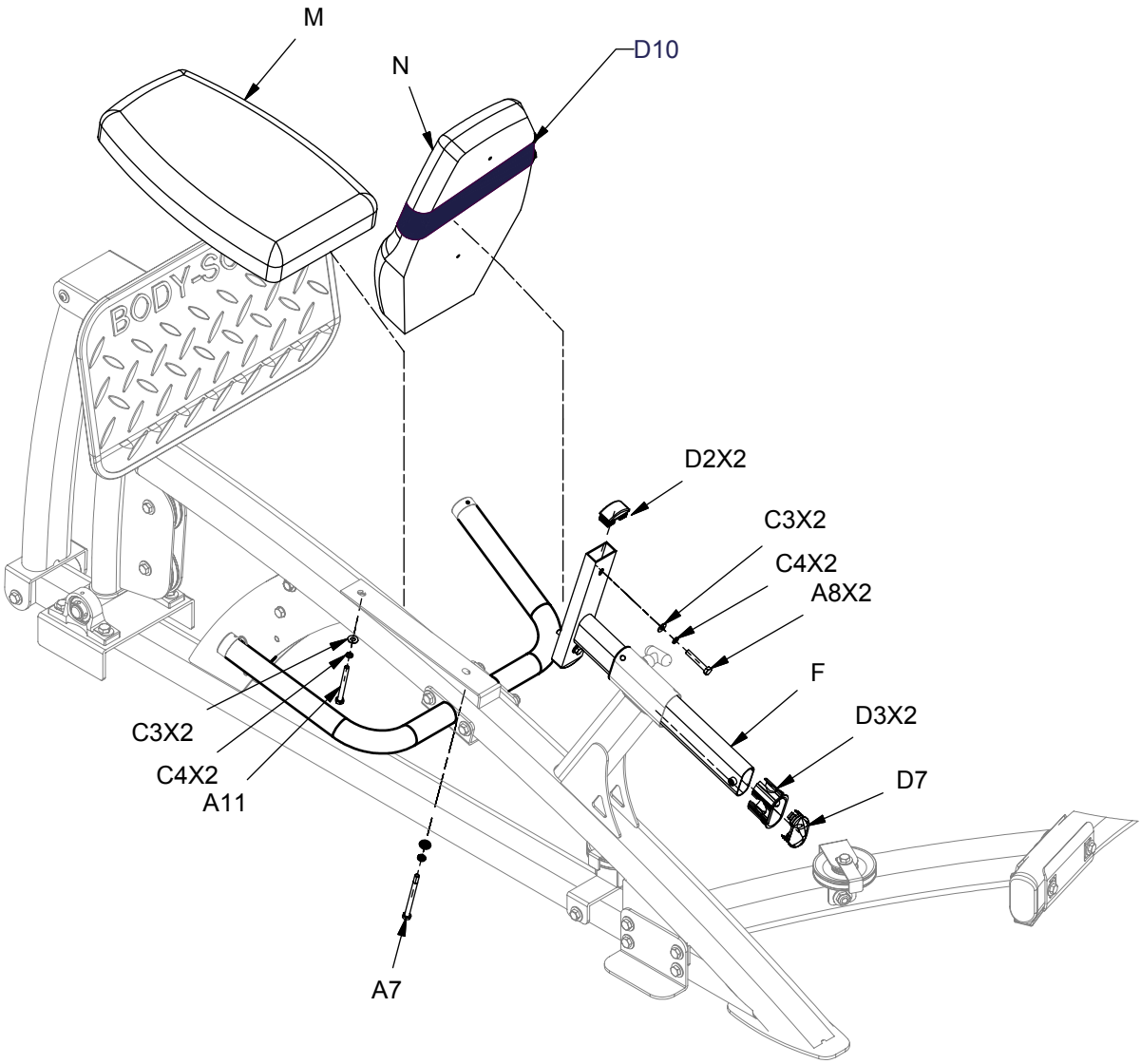
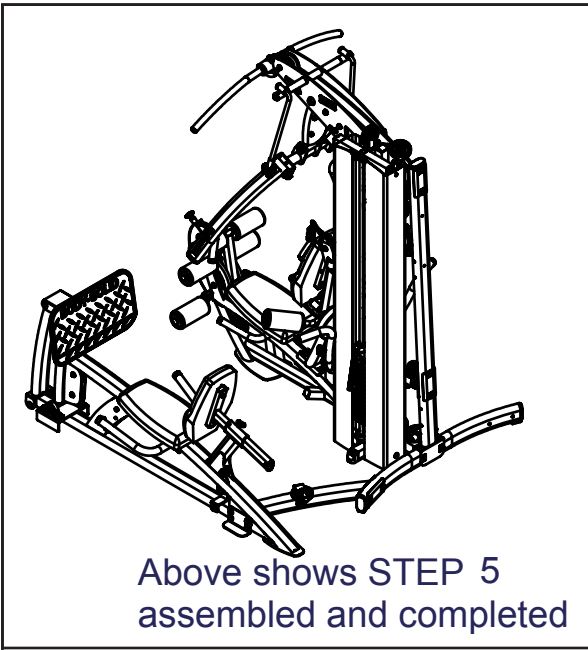

STEP**6****Be careful to assemble all components in the sequence they are presented.****NOTE:**

Finger tighten all hardware in this step. Do Not wrench tighten until end of step 6.

- A. Attach the Stamped Eye End of Cable (D6) to the gym using:
One A12 (M10x20 allen head bolt)
One B1 (M10 nylon lock nut)
- B. Route Cable (D6) across (D1-F) and (D1-E). Bring the cable under (D1-A), around (D1-D), (D1-A) and (D1-C).
- C. Connect Snap Link (D9) to the Chain Link End of steel Cable (D6).
- D. Connect Cable (D6) to Mainframe (A) as shown in Diagram B using:
One A10 (M10x60 hex head bolt)
Two C1 (M10 washer)
One B1 (M10 nylon lock nut)

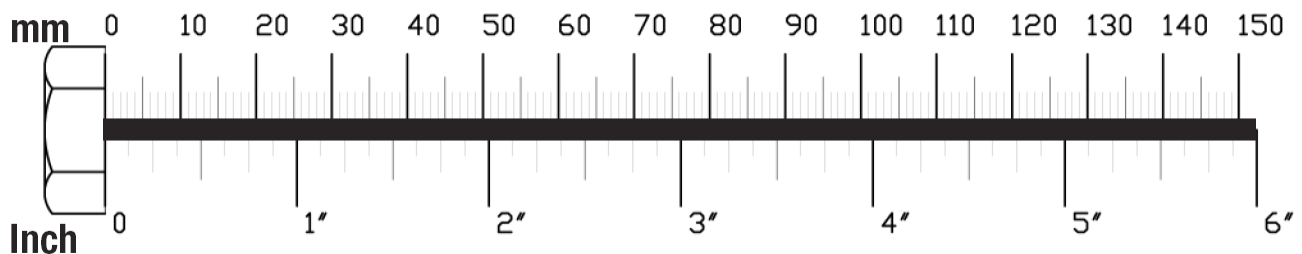

STEP
6

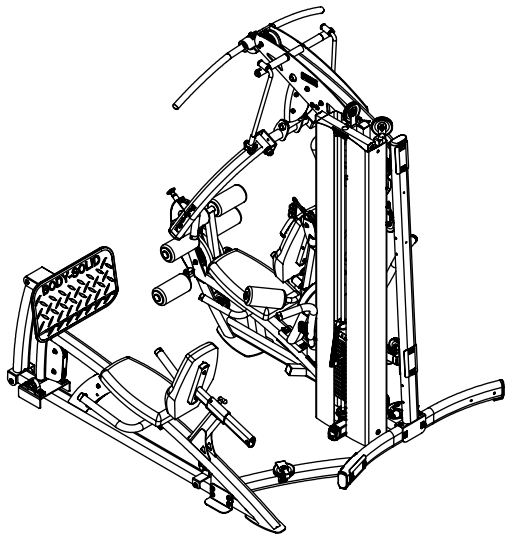

Above shows STEP 6 assembled and completed

D6. 3610mm STEEL CABLE

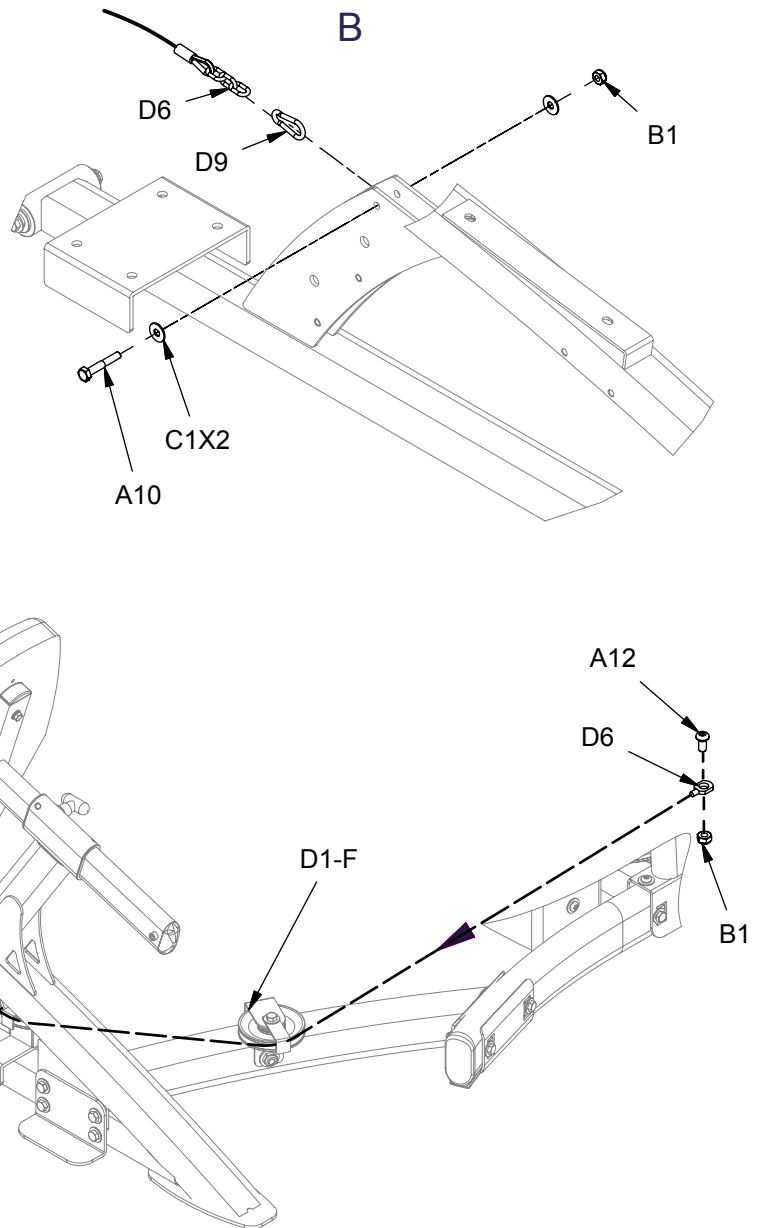
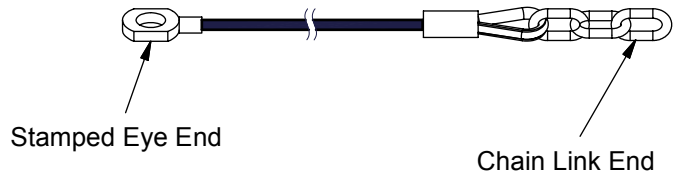

FLP Hardware

(Actual Size Shown)

A1.M10X130L HEX HEAD BOLT-----[7PCS]



A2.M12X80L HEX HEAD BOLT-----[2PCS]

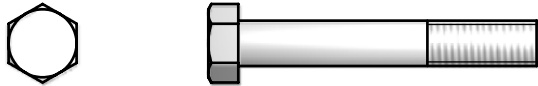

A4.M10X45L HEX HEAD BOLT-----[1PCS]



A5.M10X75L HEX HEAD BOLT-----[1PCS]

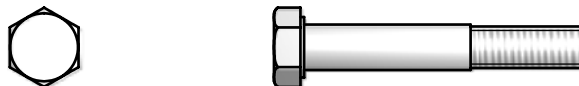

A6.M10X50L HEX HEAD BOLT-----[2PCS]



A7.M8X100L HEX HEAD BOLT-----[1PCS]



A8.M8X50L HEX HEAD BOLT-----[2PCS]



A9.M10X80L HEX HEAD BOLT-----[2PCS]

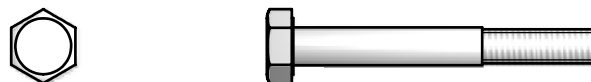

A10.M10X60L HEX HEAD BOLT-----[3PCS]



FLP Hardware

(Actual Size Shown)

A11.M8X80L HEX HEAD BOLT-----[1PCS]

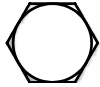

A12.M10X20L ALLEN HEAD BOLT-----[1PCS]

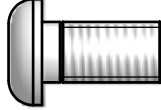
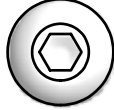

A13.M12X40L HEX HEAD BOLT-----[4PCS]

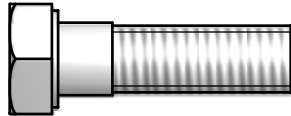

A14.M10X20L HEX HEAD BOLT-----[2PCS]

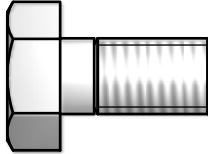
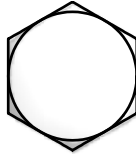

A15. M8X20L ALLEN HEAD BOLT-----[4PCS]

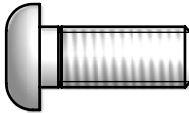
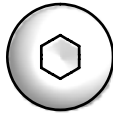

B1.M10 NYLON LOCK NUT-----[18PCS]

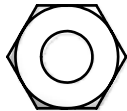

B2.M12 NYLON LOCK NUT-----[6PCS]



C1.M10 WASHER-----[31PCS]

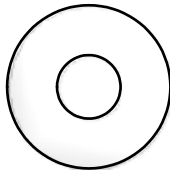

C2.M12 WASHER-----[8PCS]

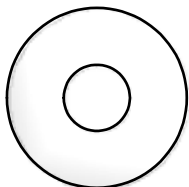

FLP Hardware

C3.M8 WASHER-----[8PCS]



C4.M8 SPRING LOCK WASHER-----[4PCS]



D1.Ø110 PULLEY (9213-002)-----[6PCS]



D2.CONVEX END CAP (9211-086)-----[2PCS]



D3.40X80 NYLON BUSHING (9211-123)-----[2PCS]



D4.CONVEX END CAP (9211-087)-----[2PCS]



D5.STEEL BUSHING(8530-014)-----[4PCS]



D6.3610mm STEEL CABLE-----[1PCS]



D7.CONVEX END CAP (9261-061)-----[1PCS]



D8.CONVEX END CAP (9211-128)-----[2PCS]



FLP Hardware

D9. SPRING SNAP LINK(8810-002)-----[1PCS]

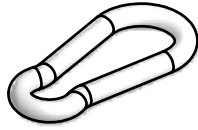

D10. PAD WRAPS (9630-134)-----[1PCS]



D11. M10 (8210-110)-----[1PCS]



D12. M8(8210-091A)-----[1PCS]



FLP Hardware

A[1PCS]

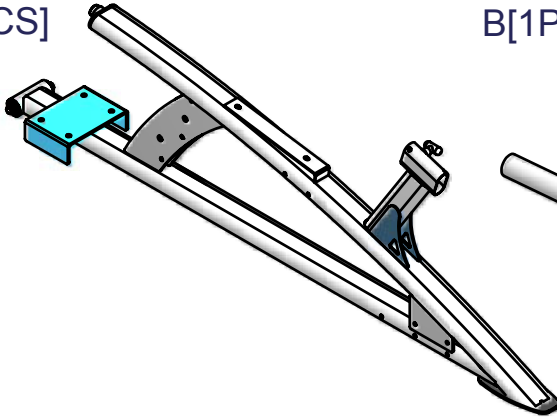

B[1PCS]

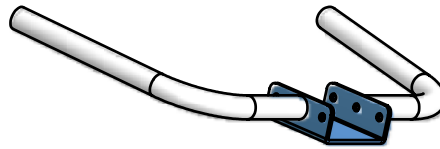

C[1PCS]

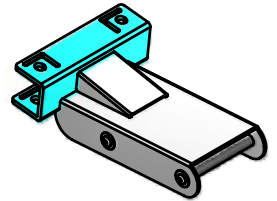

D[1PCS]

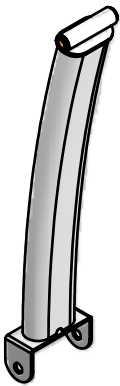

E[1PCS]

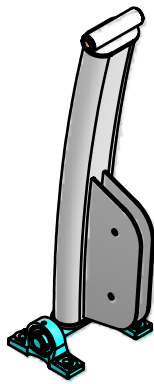

F[1PCS]

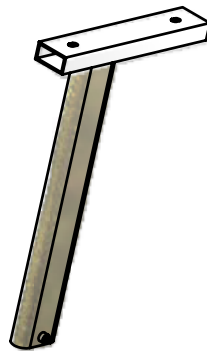

G[1PCS]

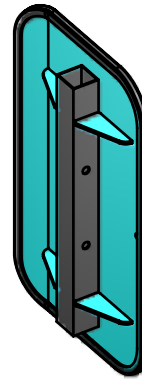

L[1PCS]

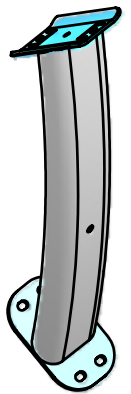

H[1PCS]

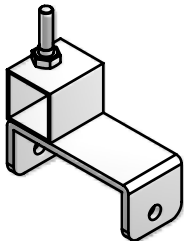

O[1PCS]

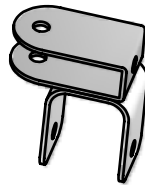

J[1PCS]

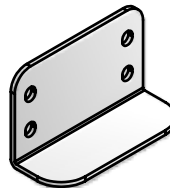

K[1PCS]

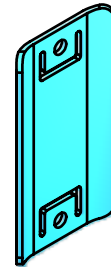

Q[2PCS]

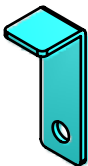

M[1PCS]

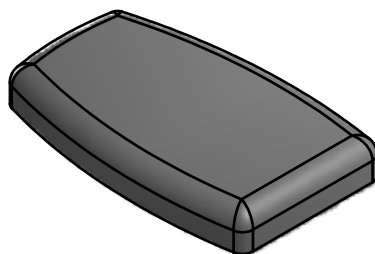

N[1PCS]

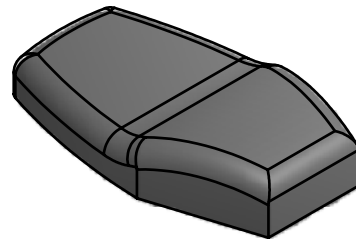

BODY-SOLID LIFETIME WARRANTY

PLEASE CONSULT YOUR PHYSICIAN BEFORE USING THIS PRODUCT.

This Warranty applies only in the United States to products manufactured or distributed by Body-Solid, Inc. (Body-Solid) under the Body-Solid brand name. The warranty period to the original purchaser is lifetime of the original purchaser.

Body-Solid warrants that the Product you have purchased for non-commercial, personal, family, or household use from Body-Solid or from an authorized Body-Solid reseller is free from defects in materials or workmanship under normal use during the warranty period. Your sales receipt, showing the date of purchase of the Product, is your proof of the date of purchase. This warranty extends only to you, the original purchaser. It is not transferable to anyone who subsequently purchases the Product from you. It excludes expendable parts such as paint and finish (ie. scratched or chipped paint; scratched, chipped, peeling or flaking chrome; rust or corrosion). This Warranty becomes VALID ONLY if the Product is assembled / installed according to the instructions / directions included with the Product.

During the warranty period Body-Solid will at no additional charge, repair or replace (at Body-Solid's option) the Product if it becomes defective, malfunctions, or otherwise fails to conform with this Warranty under normal non-commercial, personal, family, or household use. In repairing the product Body-Solid may replace defective parts or, at the option of Body-Solid, serviceable used parts that are equivalent to new parts in performance. All exchanged parts and Products replaced under this warranty will become the property of Body-Solid. Body-Solid reserves the right to change manufacturers of any part to cover any existing warranty.

To obtain warranty service, you must return the Product to Body-Solid in its original container (or equivalent). You must pre-pay any shipping charges, export taxes, customs duties and taxes, or any other charges associated with transportation of the Product. In addition, you are responsible for insuring any

Product shipped or returned. You assume the risk of loss during shipment. You must present Body-Solid with proof-of-purchase documents (including the date of purchase). Any evidence of alteration, erasing or forgery of proof-of-purchase documents will be cause to void this Warranty.

This Warranty does not extend to any Product not purchased from Body-Solid or from an authorized Body-Solid reseller. This Warranty does not extend to any Product that has been damaged or rendered defective; (a) as a result of accident, misuse, or abuse; (b) by the use of parts not manufactured or sold by Body-Solid; (c) by modification of the Product; (d) as a result of service by anyone other than Body-Solid, or an authorized Body-Solid warranty service provider. Should any product submitted for Warranty service be found to be ineligible, an estimate of repair cost will be furnished and the repair will be made if requested by you upon Body-Solid's receipt of payment.

EXCEPT AS EXPRESSLY SET FORTH IN THIS WARRANTY BODY-SOLID MAKES NO OTHER WARRANTIES, EXPRESSED OR IMPLIED INCLUDING ANY IMPLIED WARRANTIES OF MERCHANTABILITY AND FITNESS FOR A PARTICULAR PURPOSE. BODY-SOLID EXPRESSLY DISCLAIMS ALL WARRANTIES NOT STATED IN THIS WARRANTY. ANY IMPLIED WARRANTIES THAT MAY BE IMPOSED BY LAW ARE LIMITED TO THE TERMS OF THIS WARRANTY. NEITHER BODY-SOLID NOR ANY OF ITS AFFILIATES SHALL BE RESPONSIBLE FOR INCIDENTAL OR CONSEQUENTIAL DAMAGES. SOME STATES DO NOT ALLOW LIMITATIONS ON HOW LONG AN IMPLIED WARRANTY LASTS OR THE EXCLUSION OR LIMITATION OF INCIDENTAL OR CONSEQUENTIAL DAMAGES, SO THE ABOVE LIMITATIONS OR EXCLUSION MAY NOT APPLY TO YOU. This Warranty gives you specific legal rights and you may also have other rights that may vary from state to state. This is the only express warranty applicable to Body-Solid branded products. Body-Solid neither assumes nor authorizes anyone to assume for it any other express warranty.

Before returning a product you must call Body-Solid at 1-800-556-3113 to obtain a Return Authorization Number. No returns will be accepted without the Return Authorization Number. Original purchaser must pre-pay all freight charges on warranty claims. Body-Solid will not accept Freight Collect shipments or return shipments on a freight collect basis.



LIFETIME WARRANTY

Registration Card

Congratulations! You have just purchased a quality Body-Solid product. You must fill out this Warranty Registration Card completely, sign it and return it to BODY-SOLID within 30 days of purchase for this warranty to be valid.

First Name	Initial	Last Name
Street		
	Apt. No.	
City	State	Zip Code
Country	Phone	

ITEM NO. _____

ITEM NAME _____

DATE OF PURCHASE _____

1. Where did you purchase this product from?

2. Who will use this product?
___ % Male ___ % Female
3. Age of product user?
 Under 24 45-54
 25-34 55-64
 35-44 Over 65
4. Household Income?
 Under \$15,000 \$45,000 - \$60,000
 \$15,000 - \$30,000 \$60,000 - \$75,000
 \$30,000 - \$45,000 \$75,000 Plus

5. How did you learn of this product?
 TV Friend
 Radio Print ad / Flyer
 In Store Display Catalog
 Salesperson Other _____
6. Why did you choose our product?
 Quality Brand Name
 Features Price / Value
 Appearance / Style Warranty
 Design / Function Other _____

CAUTION • PLEASE NOTE • WARNING
THERE IS A RISK ASSUMED BY INDIVIDUALS
WHO USE THIS TYPE OF EQUIPMENT. TO MINIMIZE

RISK, YOU MUST FOLLOW THESE RULES:

1. Inspect equipment before each workout. Check that all nuts, bolts, screws and pop pins are in place and fully tightened. Also, before use, check cables for signs of wear. Replace all worn parts immediately. Never use machine if any parts are damaged or missing. Failure to follow these rules may result in serious injury.
2. Keep clear of the cables and all moving parts when the machine is in use.
3. Always make sure all Snap Links are closed when doing any cable / pulley exercises.
4. Exercise with care. Perform your exercises at a smooth moderate pace; never perform jerky or uncoordinated movements that may cause injury.
5. It is recommended that you should workout with a training partner.
6. Do not allow children or minors to play on or around this equipment.
7. If unsure of proper use of equipment, call your local Body-Solid distributor or the Body-Solid customer service department at 1-800-556-3113.
8. **WARNING:** Consult your physician before starting your exercise program. For your own safety, do not begin any exercise program without proper instruction.

Please sign:

Signature

Body-Solid

**LIFETIME
WARRANTY
Registration
Card**

See Details On Back.

You must complete and return Registration Card
to Body-Solid within 30 days for this Warranty to be valid.

----- ✂ ----- ✂ -----

FROM:

Name: _____

Address: _____ Apt#: _____

City: _____ State: _____ Zip Code: _____

PLACE
STAMP
HERE

BODY-SOLID, Inc.
1900 Des Plaines Avenue
Forest Park, IL 60130 USA

IMPORTANT!
Lifetime Warranty Registration Card