

SteelFlex

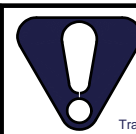
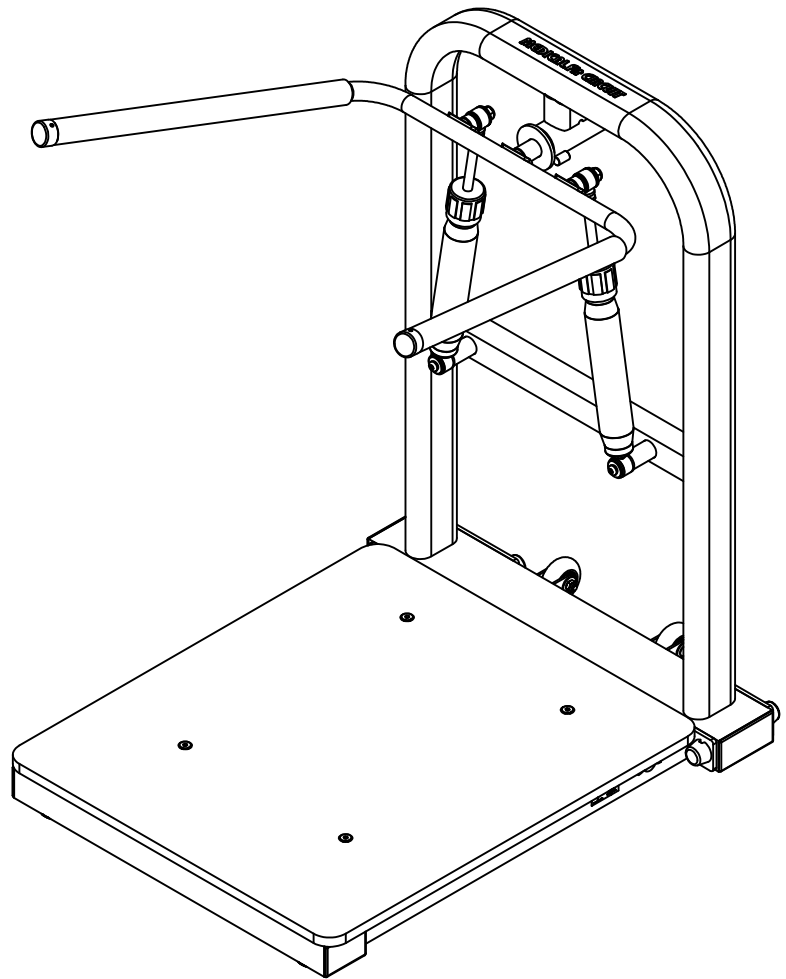

The Surgeon General
has determined that lack
of physical activity is
detrimental to your health.™

Trademark of United States Fitness Products Council

THERE IS A RISK ASSUMED BY INDIVIDUALS WHO USE THIS TYPE OF EQUIPMENT. TO MINIMIZE RISK, YOU MUST FOLLOW THESE RULES:

1. Inspect equipment before each workout. Check that all nuts, bolts, screws and pop pins are in place and fully tightened. Also, before use, check cylinders for leaking. Replace all worn parts immediately. Never use machine if any parts are damaged or missing. Failure to follow these rules may result in serious injury.
2. Keep clear of the cylinder and all moving parts when the machine is in use.
3. Exercise with care. Perform your exercises at a smooth moderate pace; never perform jerky or uncoordinated movements that may cause injury.
4. It is recommended that you should workout with a training partner.
5. Do not allow children or minors to play on or around this equipment.
6. If unsure of proper use of equipment, call your local distributor.
7. **WARNING:** Consult your physician before starting your exercise program. For your own safety do not begin any exercise program without proper instruction.

CEO-200 OWNER'S MANUAL

CEO-200 ASSEMBLY INSTRUCTIONS

HARDWARE ILLUSTRATION

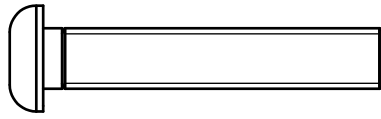
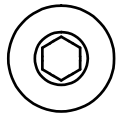

(A1)ROUND INNER HEX SCREW M8X45L PARTIAL QTY.2

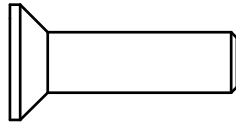
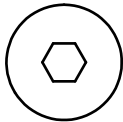

(A2)ROUND INNER HEX SCREW M8X40L PARTIAL QTY.4

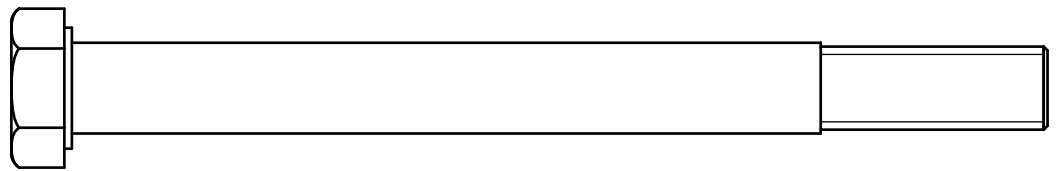
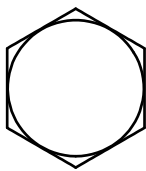

(A3)HEX BOLT M12X130L PARTIAL QTY.4

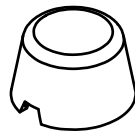

(A4)BOLT CAP(9212-024) QTY.8

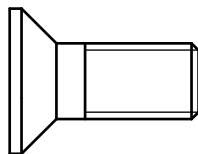
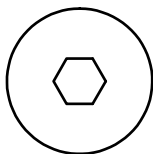

(A5)M10X25L SOCKER FLAT SCREW QTY.1

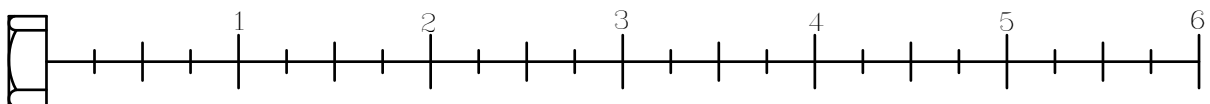

CEO-200 ASSEMBLY INSTRUCTIONS

HARDWARE ILLUSTRATION

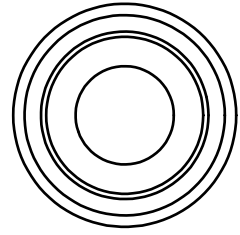
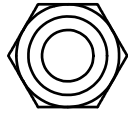
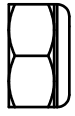

(B1) M8 NYLON LOCK NUT QTY.2 (C3) 1/2" ROUND END CAP WASHER QTY.8

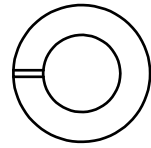
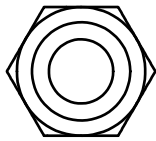
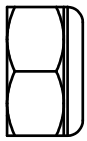

(B2) M10 NYLON LOCK NUT QTY.2 (C4) M10 SPRING WASHER QTY.2

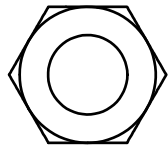
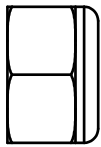

(B2) M12 NYLON LOCK NUT QTY.4

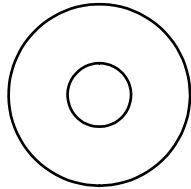

(C1) M8 (I.D.) FLAT WASHER Ø24 QTY.4

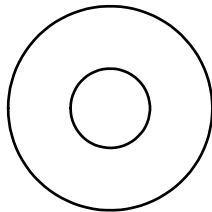

(C2) M10 (I.D.) FLAT WASHER Ø27 QTY.2

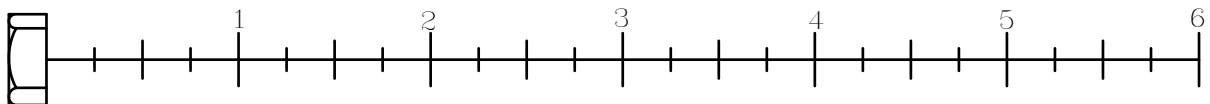

CEO-200 ASSEMBLY INSTRUCTIONS

HARDWARE ILLUSTRATION

(D1)Ø50X10 END COVER(8130-131)	-----	[1PCS]
(D2)CU WASHER(8520-008)	-----	[1PCS]
(D3)50X75 FLAT END CAP(9211-012)	-----	[2PCS]
(D4)50X100 FLAT END CAP(9211-014)	-----	[2PCS]
(D5)Ø64 PULLEY(9213-023)	-----	[2PCS]
(D6)Ø60X42H DECK BUFFER(9214-037)	-----	[4PCS]

D1.

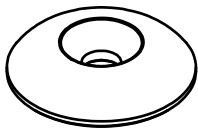

D2.

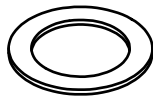

D3.

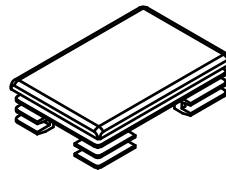

D4.

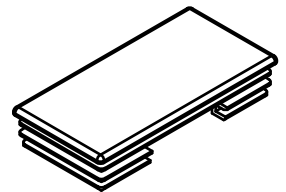

D5.

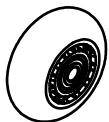

D6.

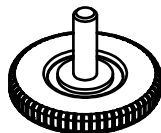

CEO-200 ASSEMBLY INSTRUCTIONS

PARTS ILLUSTRATION SHEET

A[1SET]

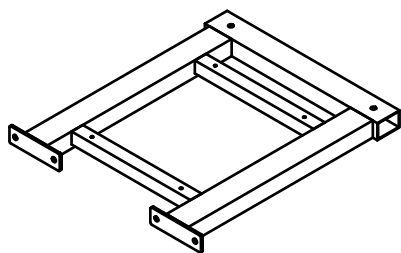

B[1SET]

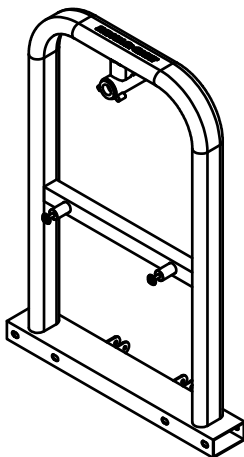

C[1SET]

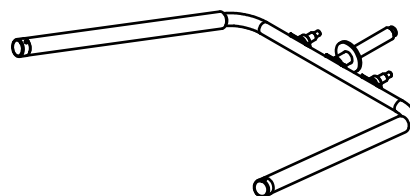

D[1PCS]
9710-020

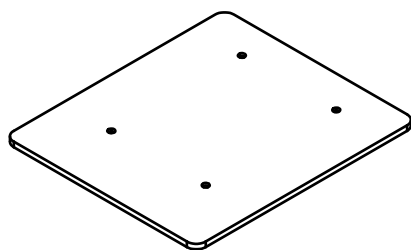

E[2PCS]
8830-020

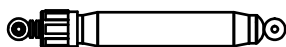

F[2PCS]
8312-091

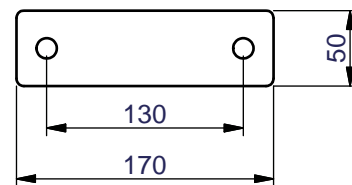

CEO-200 ASSEMBLY INSTRUCTIONS

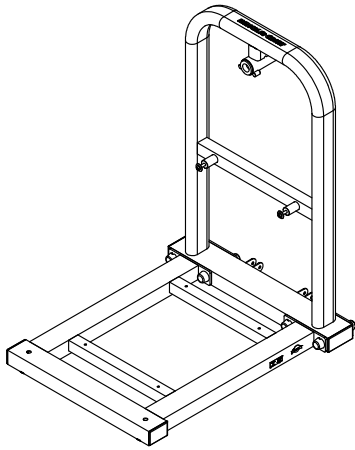

Above shows STEP1
assembled and completed

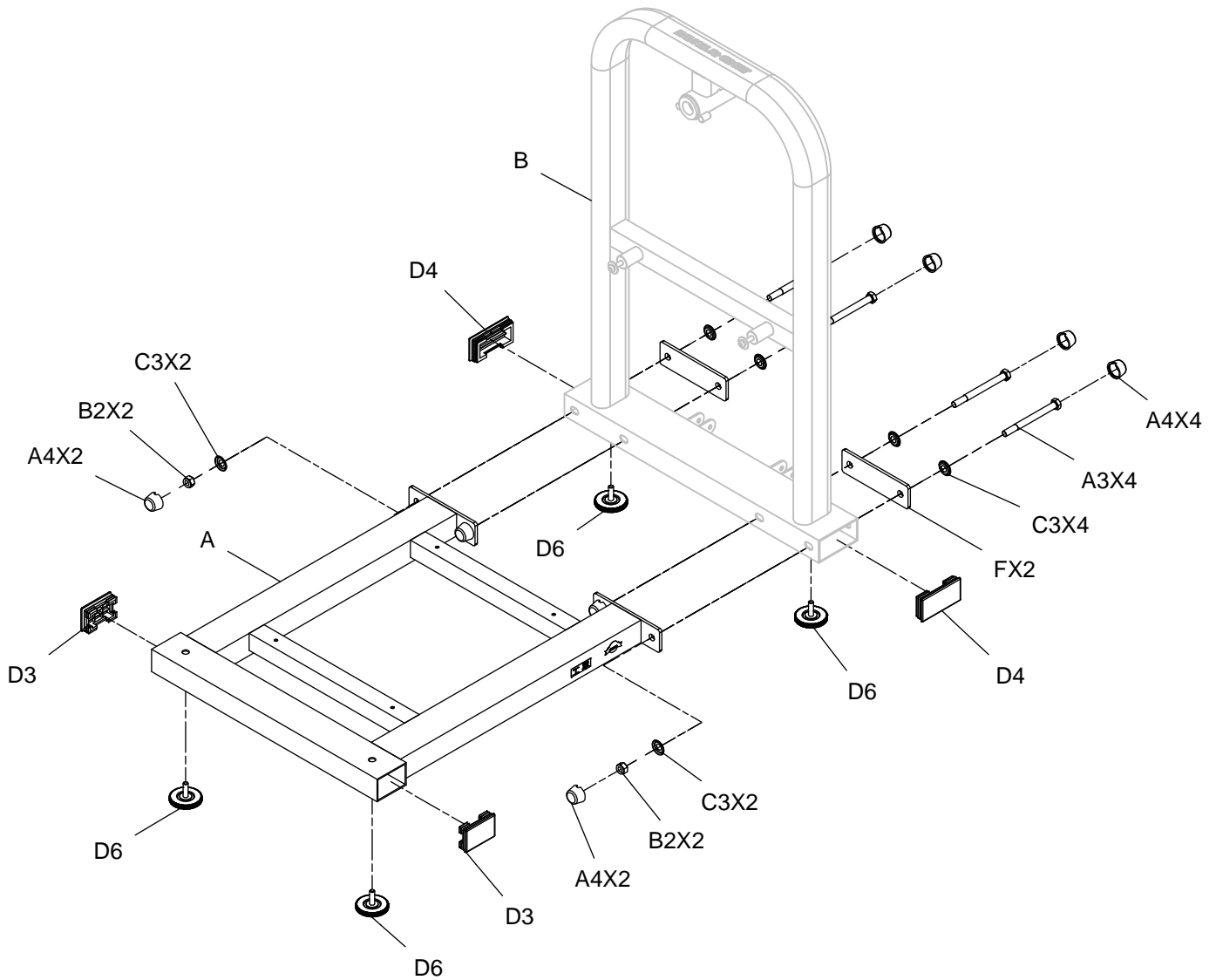

CEO-200 ASSEMBLY INSTRUCTIONS

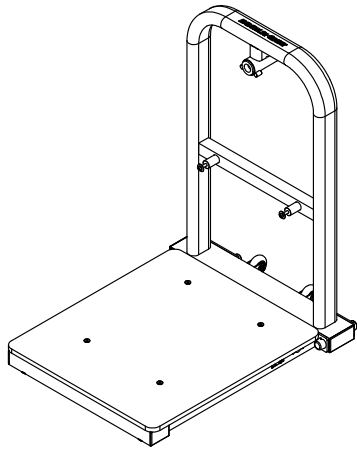

Above shows STEP2
assembled and completed

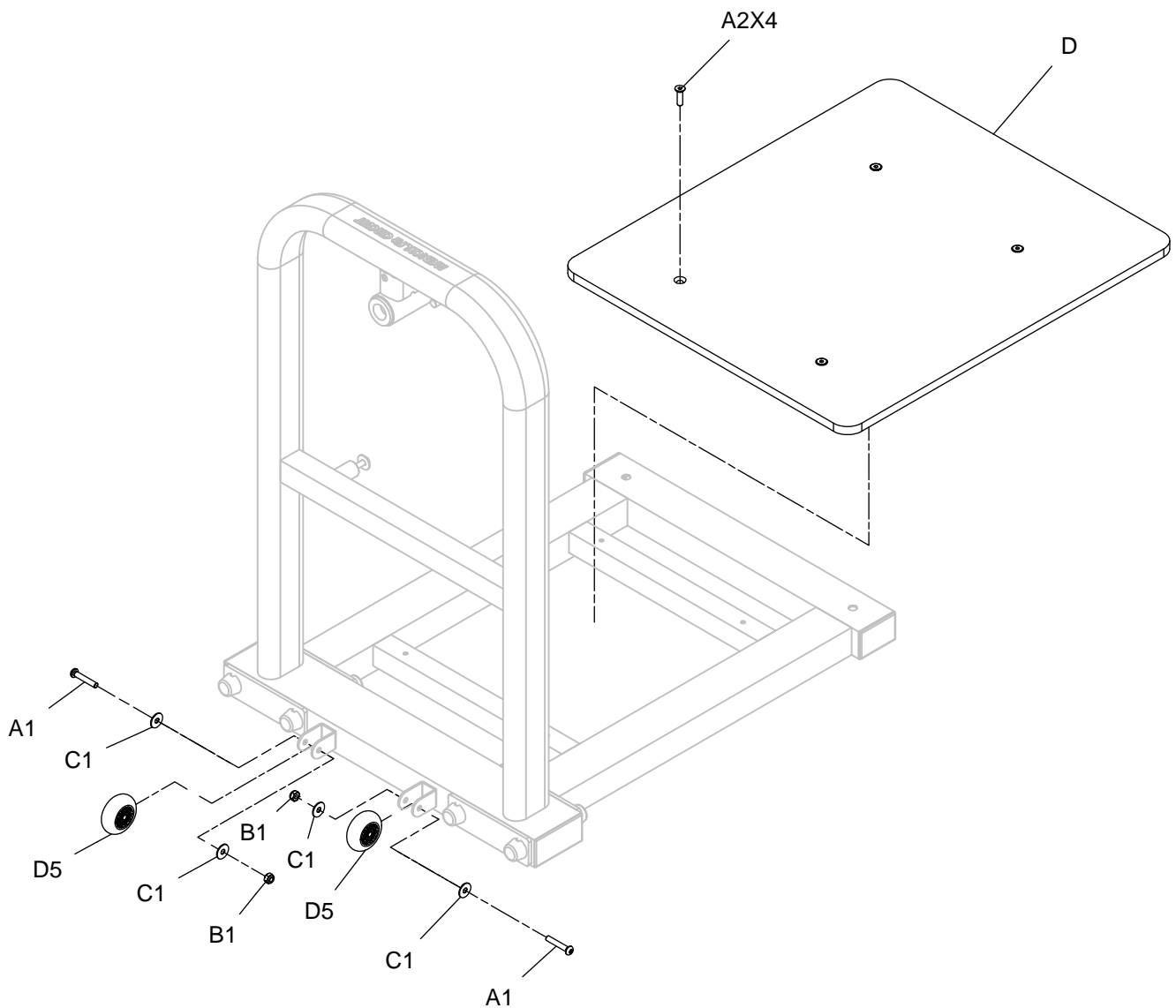

CEO-200 ASSEMBLY INSTRUCTIONS

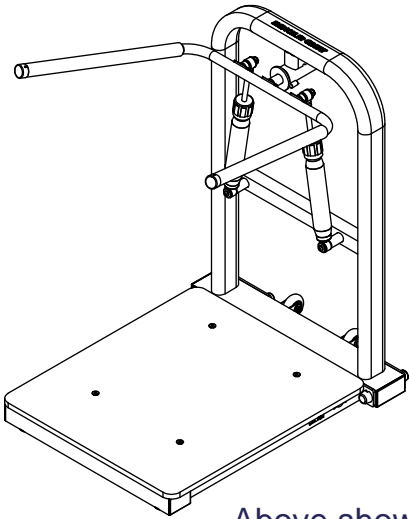

Above shows STEP3
assembled and completed

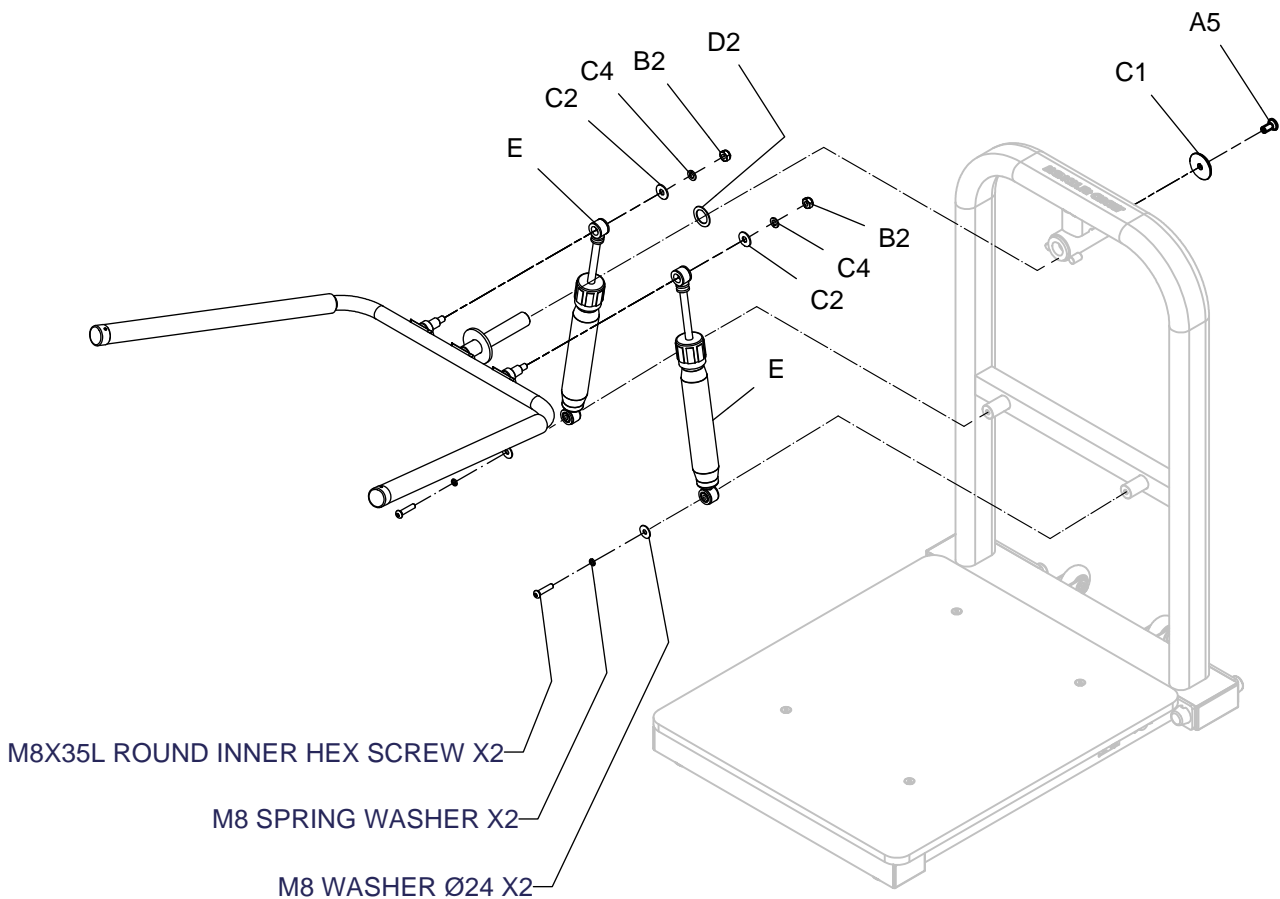

Cylinder Description and Assembly Instruction

※This model of cylinder contains a spring inside so it can not be pulled out by hand directly.

Part No.8830-016

Adapt Model: CLP-600

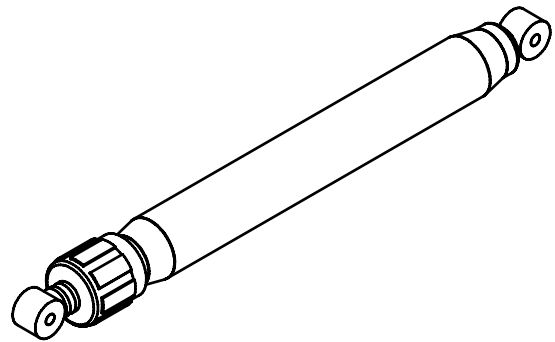
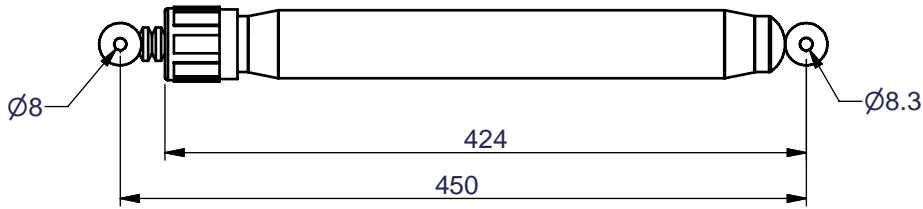

※This cylinder does not contain a spring, and it can be pulled out directly by hand.

Part No. 8830-017

Adapt Model: CBP300 · CLE500 · CAC700 · CSP900 · CAB1000

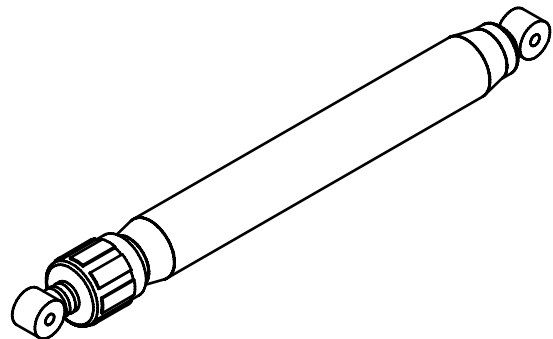
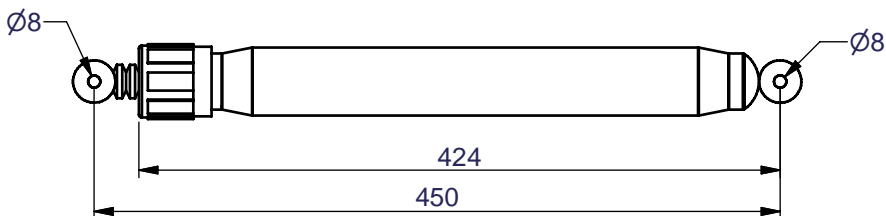

Cylinder Description and Assembly Instruction

- ※This cylinder does not contain a spring, and it can be pulled out directly by hand.
- ※No attached iron bush $\text{OD}\phi 16\text{X ID}\phi 8\text{X}22.5\text{L}$
- Part No. 8830-020
- Adapt Model: CEO-200, CPD-800

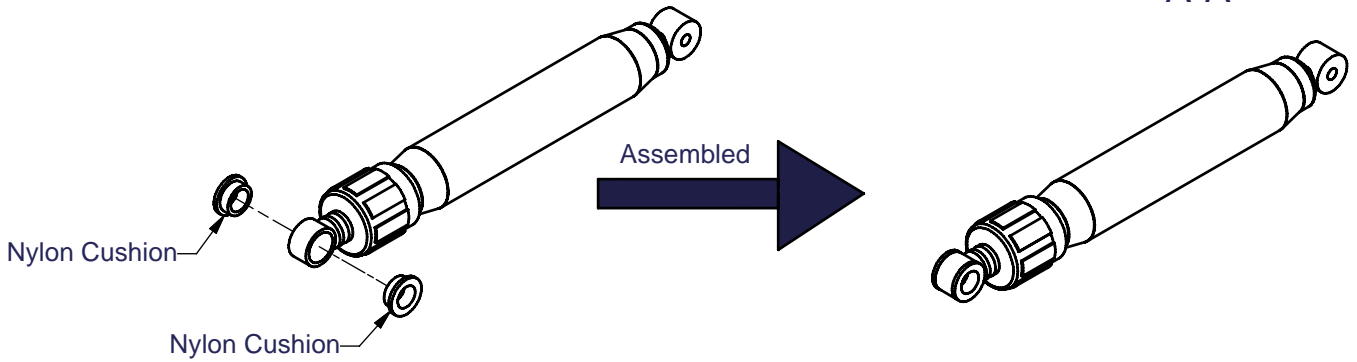
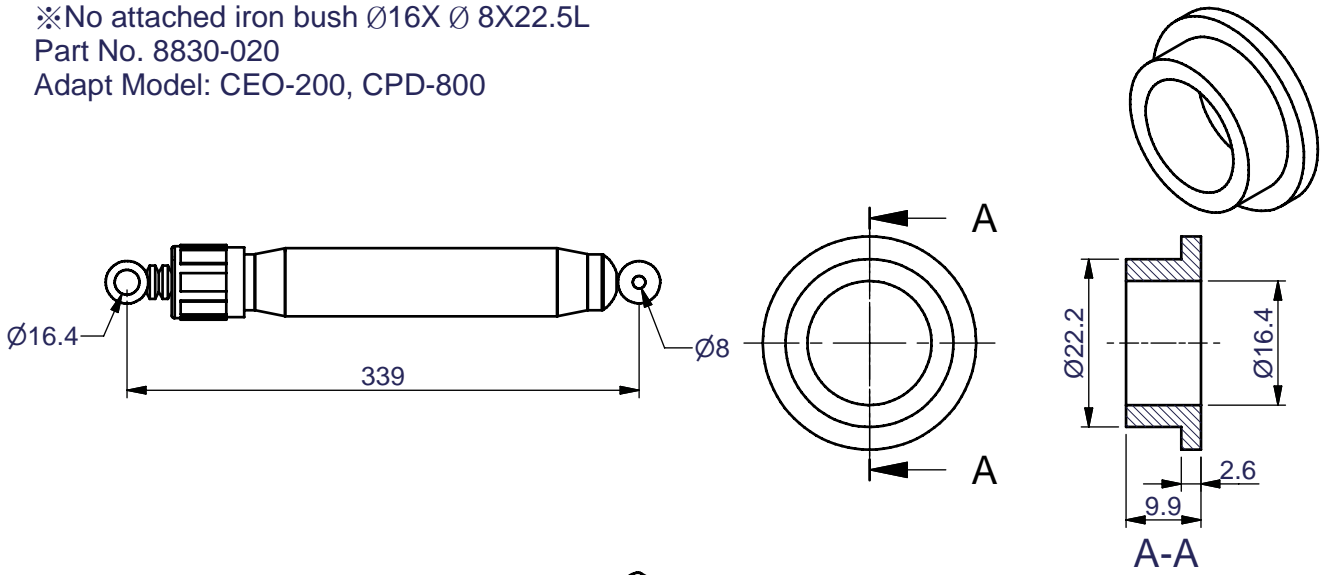

- ※This cylinder does not contain a spring, and it can be pulled out directly by hand.
- ※With attached iron bush $\text{OD}\phi 16\text{X ID}\phi 8\text{X}22.5\text{L}$
- Part No. 8830-020
- Adapt Model: CBC-400, CTH-1100

