

Body-Solid

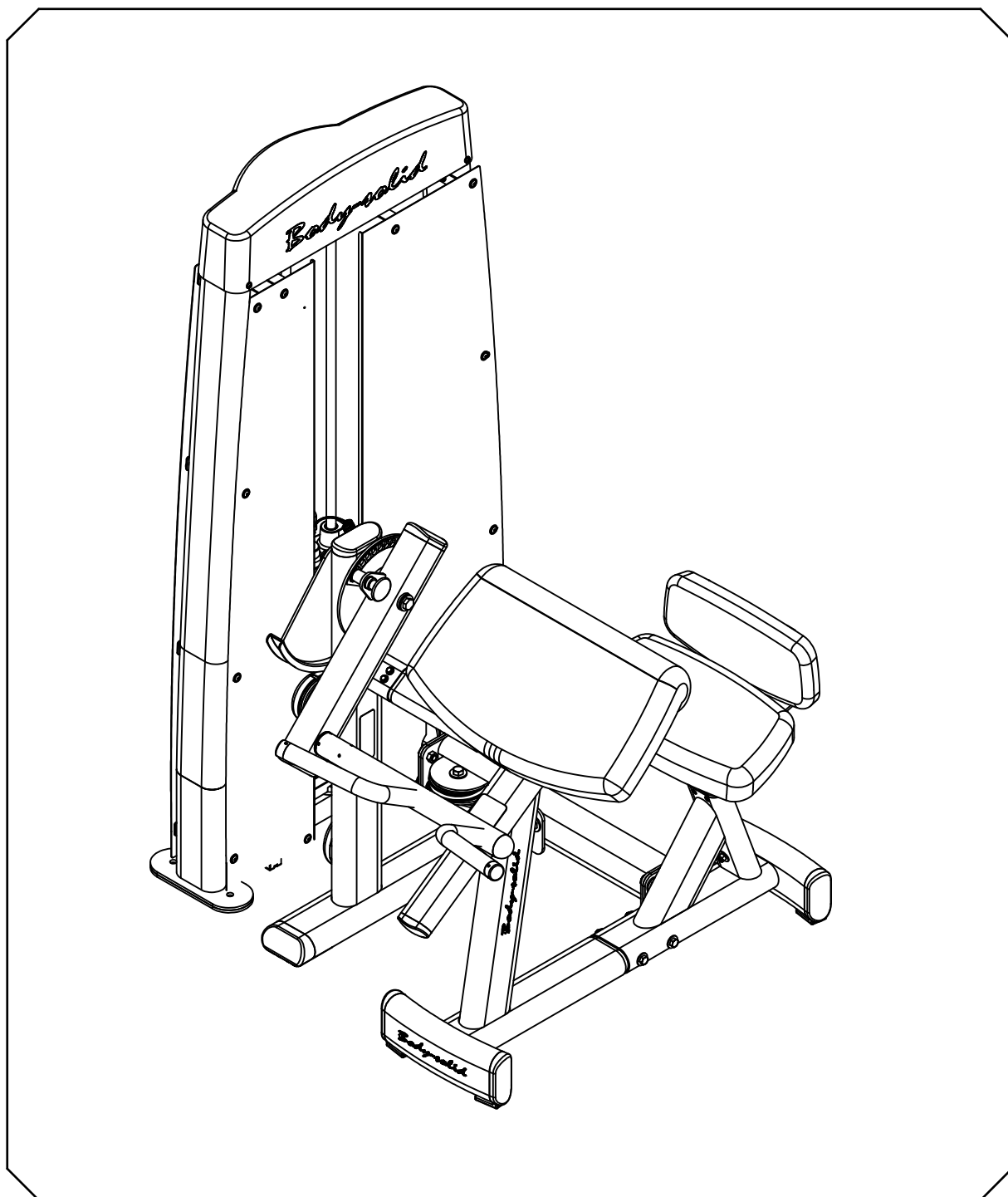

BODY-SOLID, Inc.
1900 S. Des Plaines Ave.
Forest Park, IL 60130 USA
Phone: (708) 427-3555
Fax: (708) 427-3556
www.bodysolid.com

DBTC.4 OWNER'S MANUAL

DBTC ASSEMBLY INSTRUCTIONS

HARDWARW ILLUSTRATION

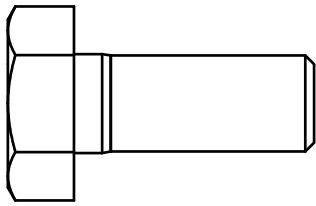

(A1)HEX BOLT 1/2"X1-1/4"L PARTIAL QTY.5

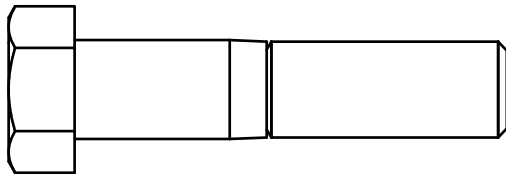

(A2)HEX BOLT 1/2"X2-1/4"L PARTIAL QTY.1

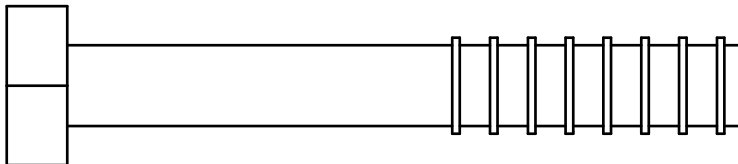

(A3)HEX BOLT 1/2"X3-1/2"L PARTIAL QTY.1

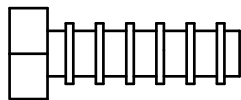

(A4)HEX BOLT 5/16"X1"L PARTIAL QTY.12

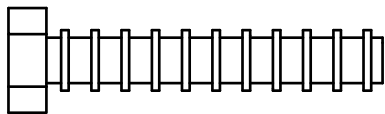

(A5)HEX BOLT 5/16"X1-3/4"L PARTIAL QTY.1

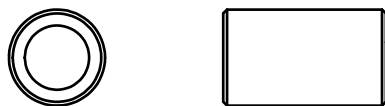

(A6)STEEL BUSHING \varnothing 1/2"X \varnothing 8.5X21L QTY.1

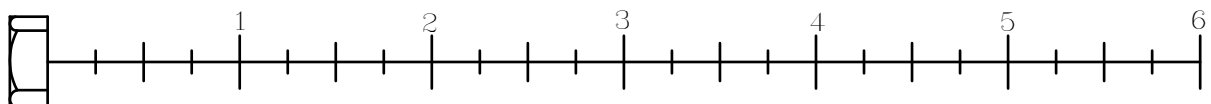

DBTC ASSEMBLY INSTRUCTIONS

HARDWARW ILLUSTRATION

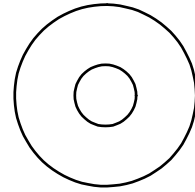
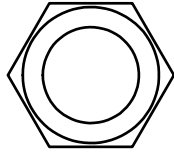
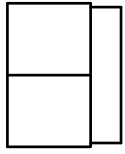

(B1) NYLON LOCK NUT 1/2" QTY.7

(C4) 5/16" (I.D.) FLAT WASHER \varnothing 24 QTY.12

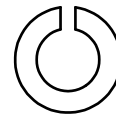
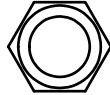

(B2) NYLON LOCK NUT 5/16" QTY.1

(C5) SPRING WASHER 5/16" QTY.12

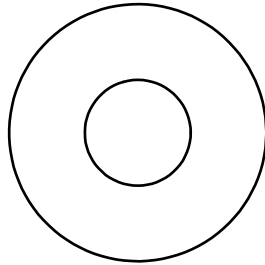

(C1) 1/2" (I.D.) FLAT WASHER \varnothing 34 QTY.8

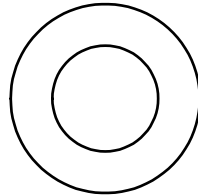

(C2) 1/2" (I.D.) FLAT WASHER \varnothing 25 QTY.6

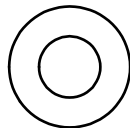

(C3) 5/16" (I.D.) FLAT WASHER \varnothing 16 QTY.2

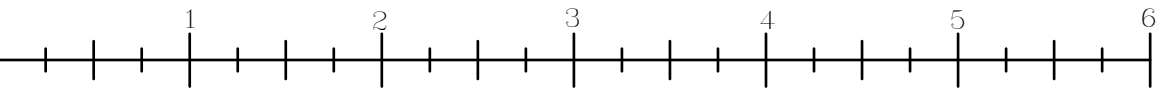

DBTC ASSEMBLY INSTRUCTIONS

HARDWARW ILLUSTRATION

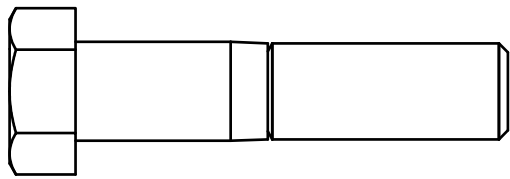

(AA2)HEX BOLT 1/2"X2-1/4"L PARTIAL QTY.3

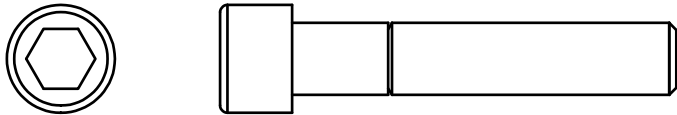

(AA4)ROUND INNER HEAD 3/8"X2"L PARTIAL QTY.1

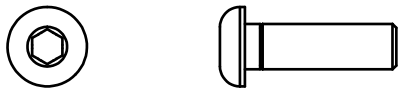

(AA5)ROUND INNER HEX SCREW M6X20L PARTIAL QTY.20

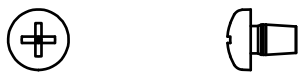

(AA6)ROUND CROSS SCREW 5/32"X1/4"L PARTIAL QTY.4

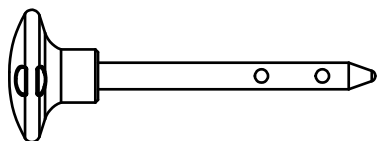

(AA7)10LB PIN(8250-071) QTY.1

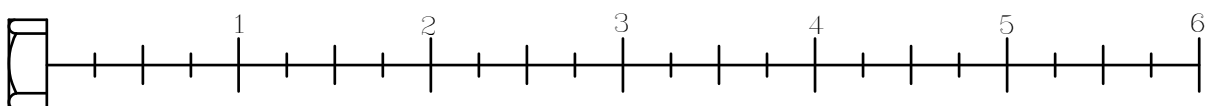

DBTC ASSEMBLY INSTRUCTIONS

HARDWARW ILLUSTRATION

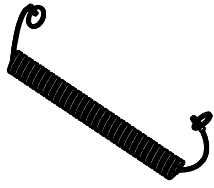

(AA8)ELASTIC BOLT QTY.1

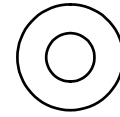

(CC2)M6(I.D.)FLAT WASHER Ø13 QTY.20

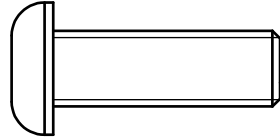
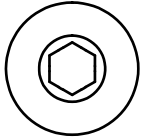

(AA10)ROUND INNER HEX SCREW
M10X30L PARTIAL QTY.1

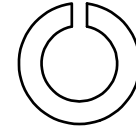

(CC5)SPRING WASHER 3/8" QTY.1

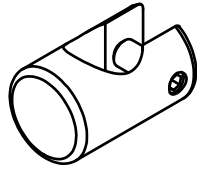

(AA11)FIRM SHEATH(8890-046) QTY.1

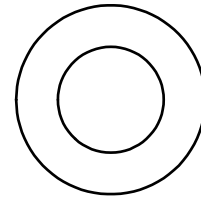

(CC6)1/2"(I.D.)FLAT WASHER Ø25 QTY.2

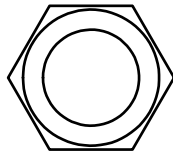
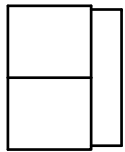

(BB2)NYLON LOCK NUT1/2" QTY.3

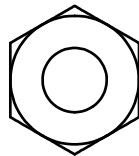
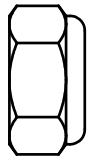

(BB3)NYLON LOCK NUT M10 QTY.1

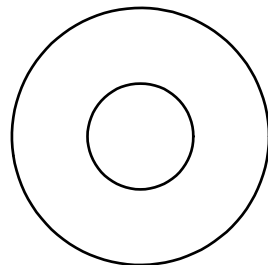

(CC1)1/2"(I.D.)FLAT WASHER Ø34 QTY.4

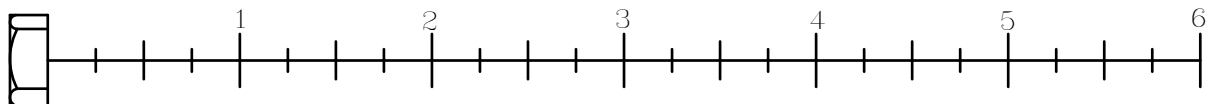

DBTC ASSEMBLY INSTRUCTIONS

HARDWARW ILLUSTRATION

D1



D2



D3



D4

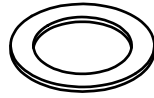

D5

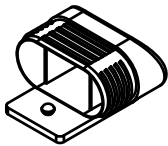

D6

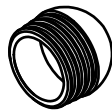

D7

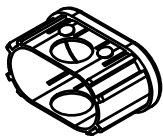

D8



D9



D10



D11



D12

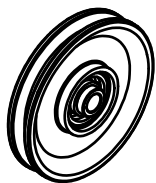

D13

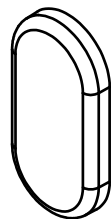

D14

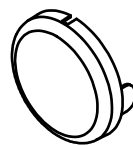

D15

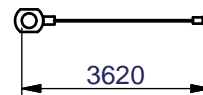

D16

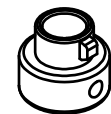

D17

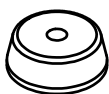

D18

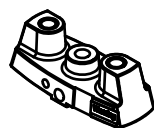

D20

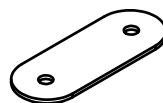

D22

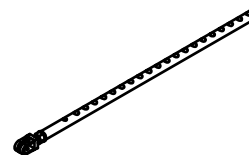

(D1)Ø3/4"X13.5X8L STEEL BUSHING(8110-014)-----	[2PCS]
(D2)Ø38"XØ25.2X27L STEEL BUSHING(8130-159)-----	[1PCS]
(D3)Ø30"XØ20X1.5t CU WASHER(8520-007)-----	[1PCS]
(D4)Ø38"XØ26X1.5t CU WASHER(8520-008)-----	[1PCS]
(D5)58X116X2.5t FOOT CAP(9211-109)-----	[1PCS]
(D6)Ø50 ROUND END CAP(9211-074)-----	[1PCS]
(D7)50X100 NYLON BUSHING(9211-107)-----	[2PCS]
(D8)58X116X2.5t FOOT CAP(9211-108)-----	[4PCS]
(D9)58X116X2.5t END CAP(9211-112)-----	[3PCS]
(D10)40X80X2t END CAP(9211-113)-----	[2PCS]
(D11)Ø4" PULLEY(9213-017A)-----	[2PCS]
(D12)Ø4" 1/2"PULLEY(9213-010B)-----	[5PCS]
(D13)207X105X25 END CAP(9211-115)-----	[1PCS]
(D14)Ø131X30 END CAP(9211-116)-----	[1PCS]
(D15)3620mm STEEL CABLE(FDBTCA)-----	[1PCS]
(D16)Ø3/4" SHAFT COLLAR(9211-046)-----	[2PCS]
(D17)Ø4" RUBBER DOUNT(9310-017)-----	[2PCS]
(D18)TOP PLATE(8400-006)-----	[1PCS]
(D20)95X250 RUBBER PAD(9310-060)-----	[2PCS]
(D21)DBTC FOR DGYM STEEL CABLE(FDBTCB)-----	[1PCS]
(D22)WEIGHT SELECTOR BAR(8210-042B)-----	[1PCS]

DBTC ASSEMBLY INSTRUCTIONS

PARTS ILLUSTRATION

A2 [1PCS]

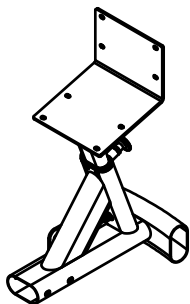

B [1PCS]

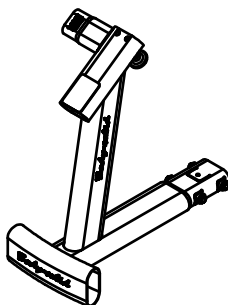

C [1PCS]

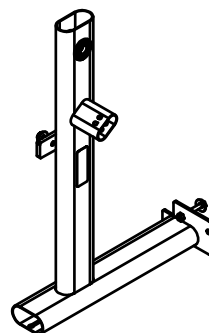

D [1PCS]

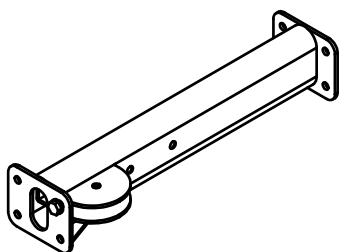

F2 [1PCS]

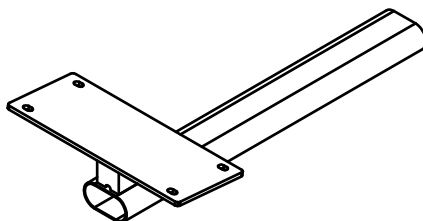

G1 [1PCS]

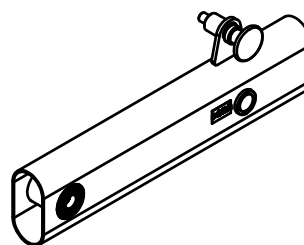

H1 [1PCS]

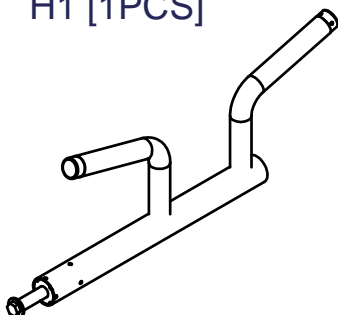

I [1PCS]

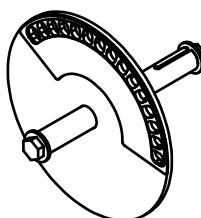

J [1PCS]

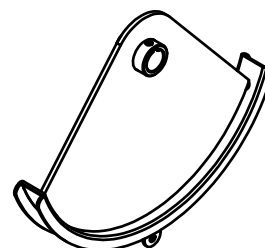

K [1PCS]
13CPTB

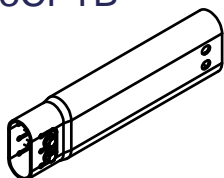

L [1PCS]
8312-062

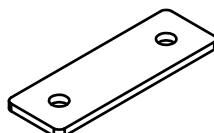

M [1PCS]
9132-019

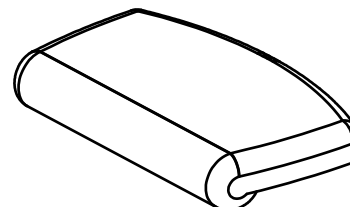

N [1PCS]
9122-038

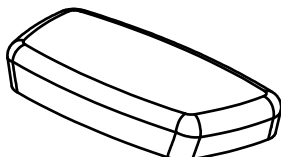

O [1PCS]
9111-060

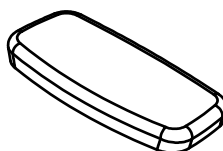

P [1PCS]
9440-162

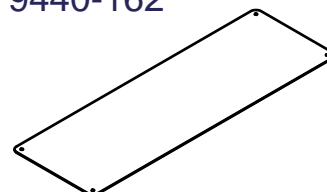

DBTC ASSEMBLY INSTRUCTIONS

PARTS ILLUSTRATION

AA[1PCS]
6610-002

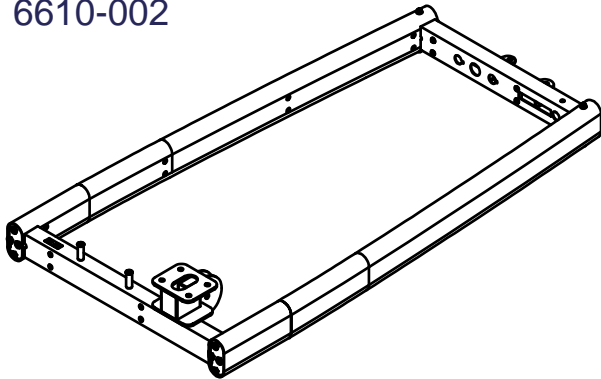

AB[1PCS]
8380-046

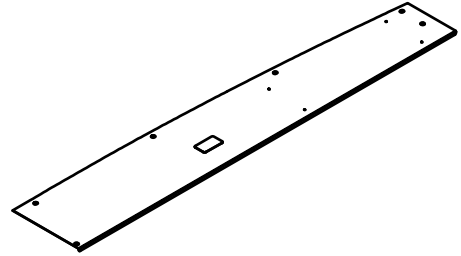

AC[1PCS]
8380-047

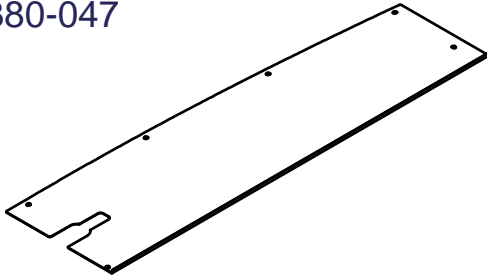

AD[1PCS]
8380-048

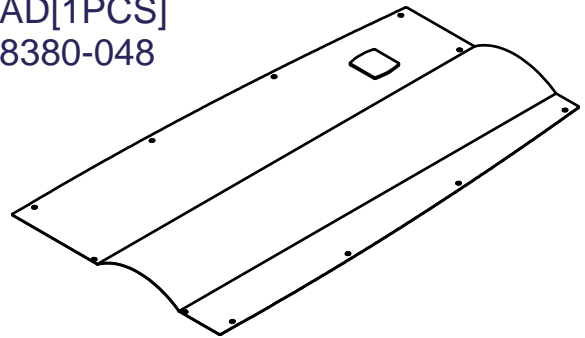

AE[2PCS]
260158A $\varnothing 3/4$ "X1.6tX1407L



AK[1PCS]
9211-111A

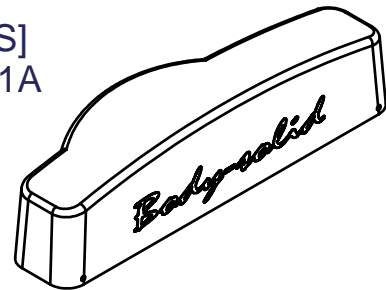

AG[2PCS]
8313-144

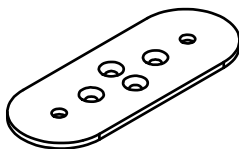

AH[9PCS]
8321-040

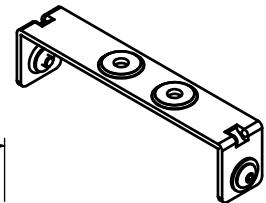
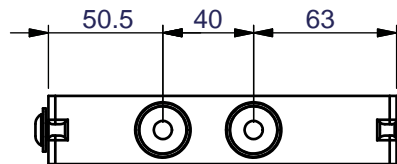

AI[1PCS]
8321-040

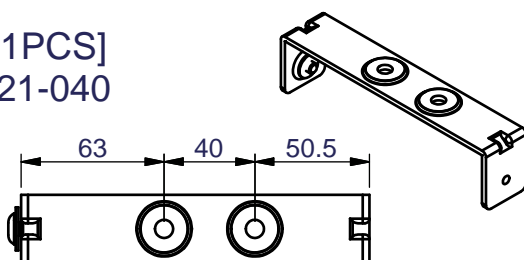

AJ[2PCS]
8321-040

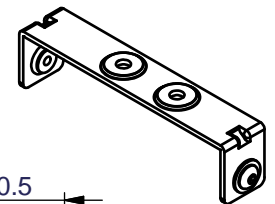
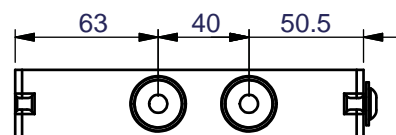

DBTC ASSEMBLY INSTRUCTIONS

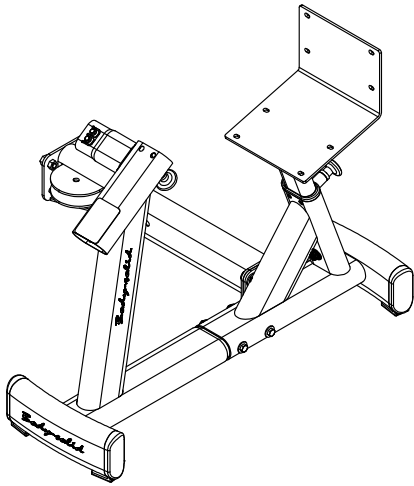

Above shows STEP 1 assembled and completed

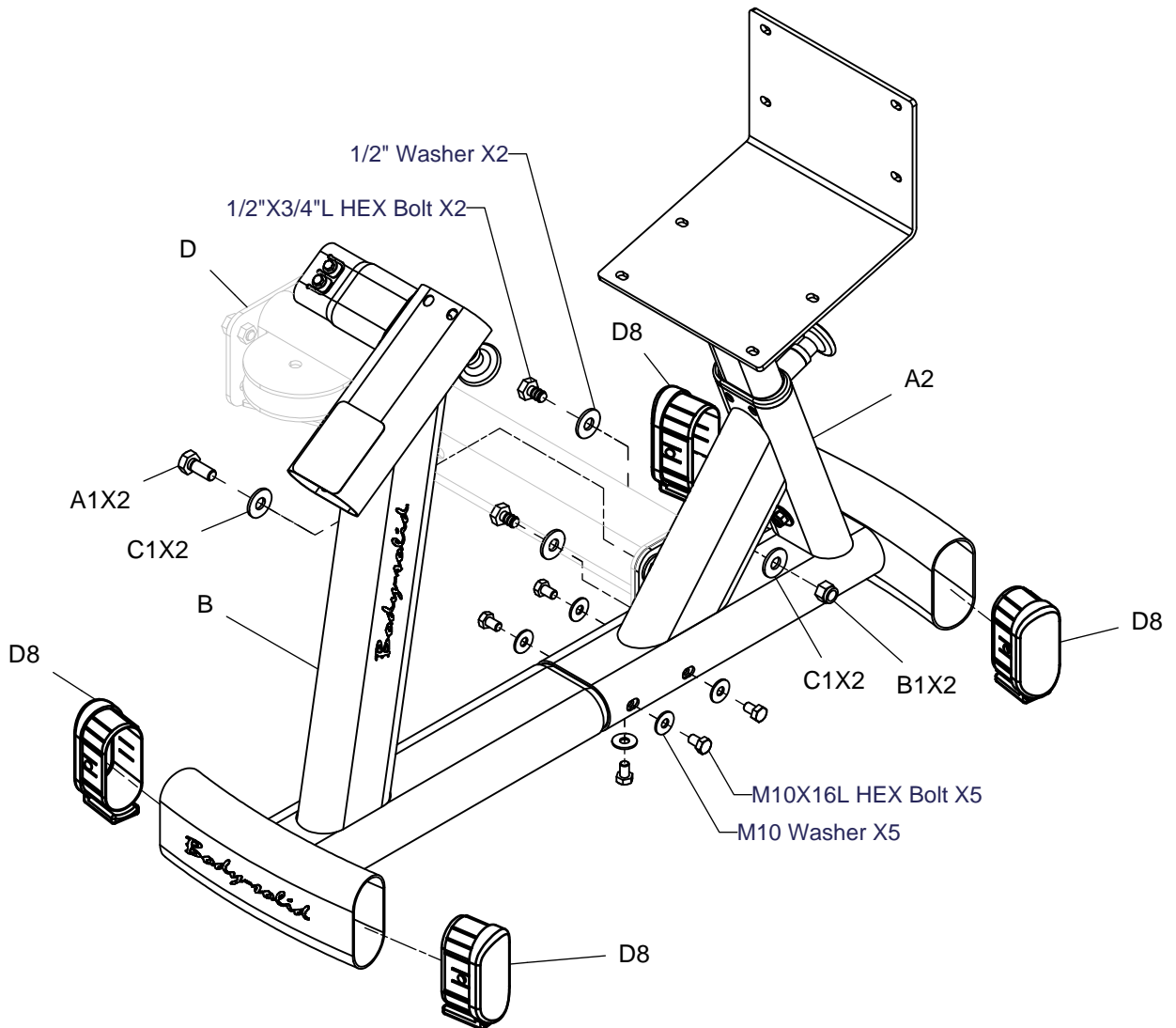

DBTC ASSEMBLY INSTRUCTIONS

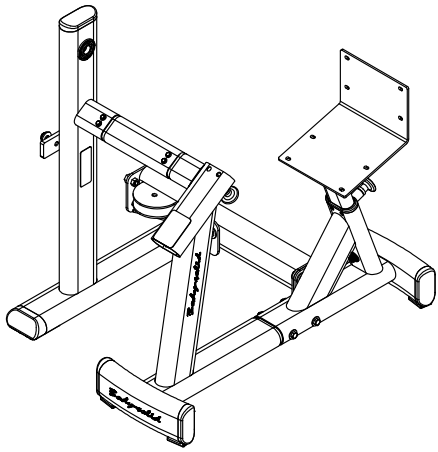

Above shows STEP2 assembled and completed

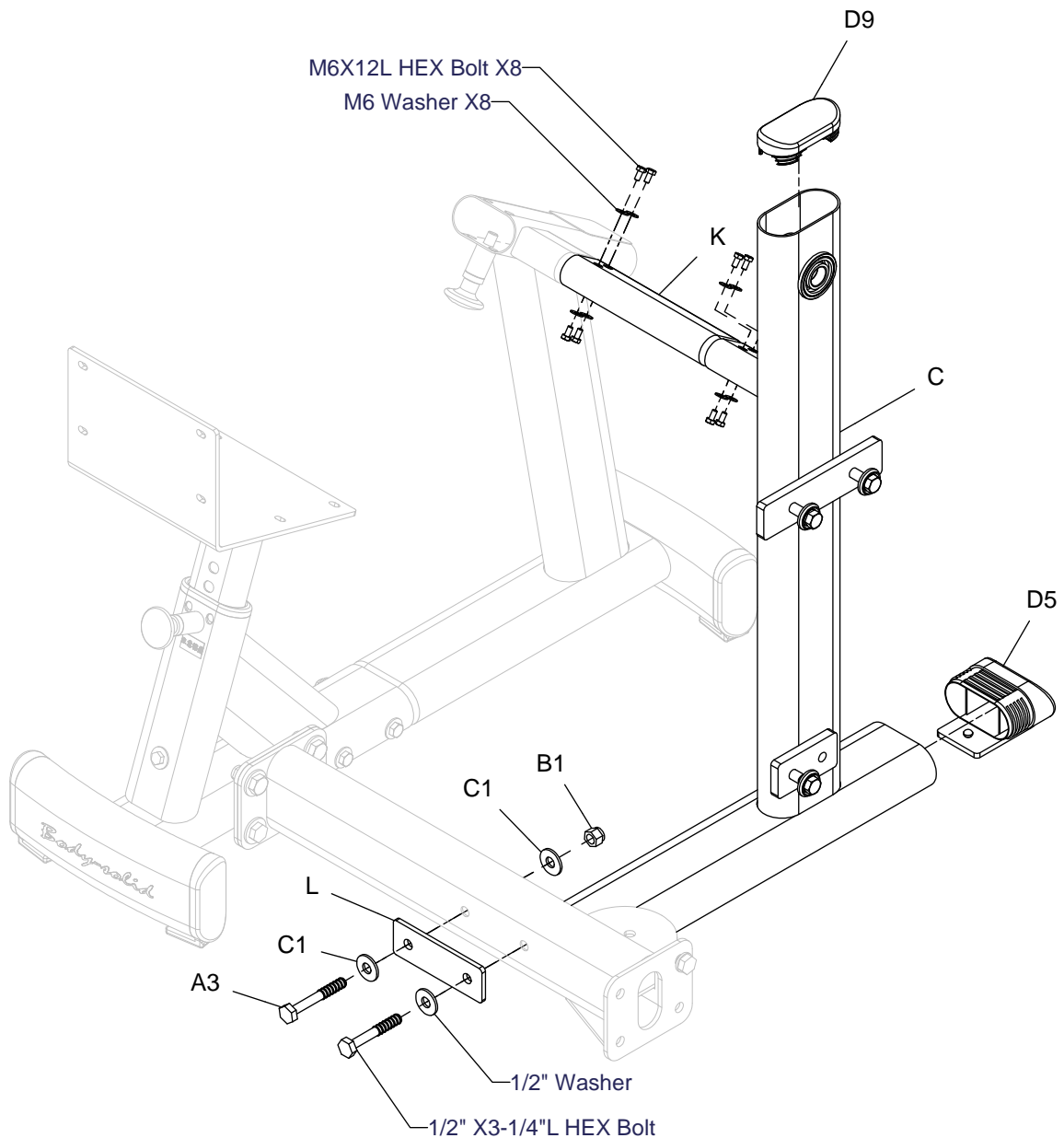

DBTC ASSEMBLY INSTRUCTIONS

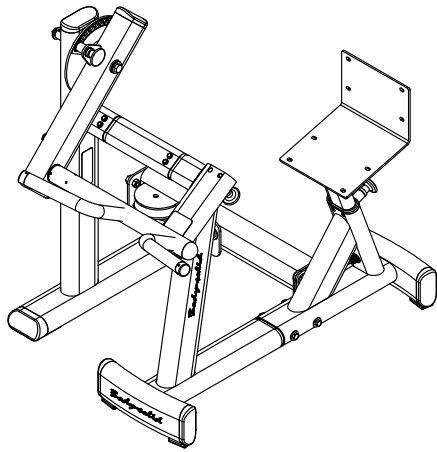

Above shows STEP 3 assembled and completed

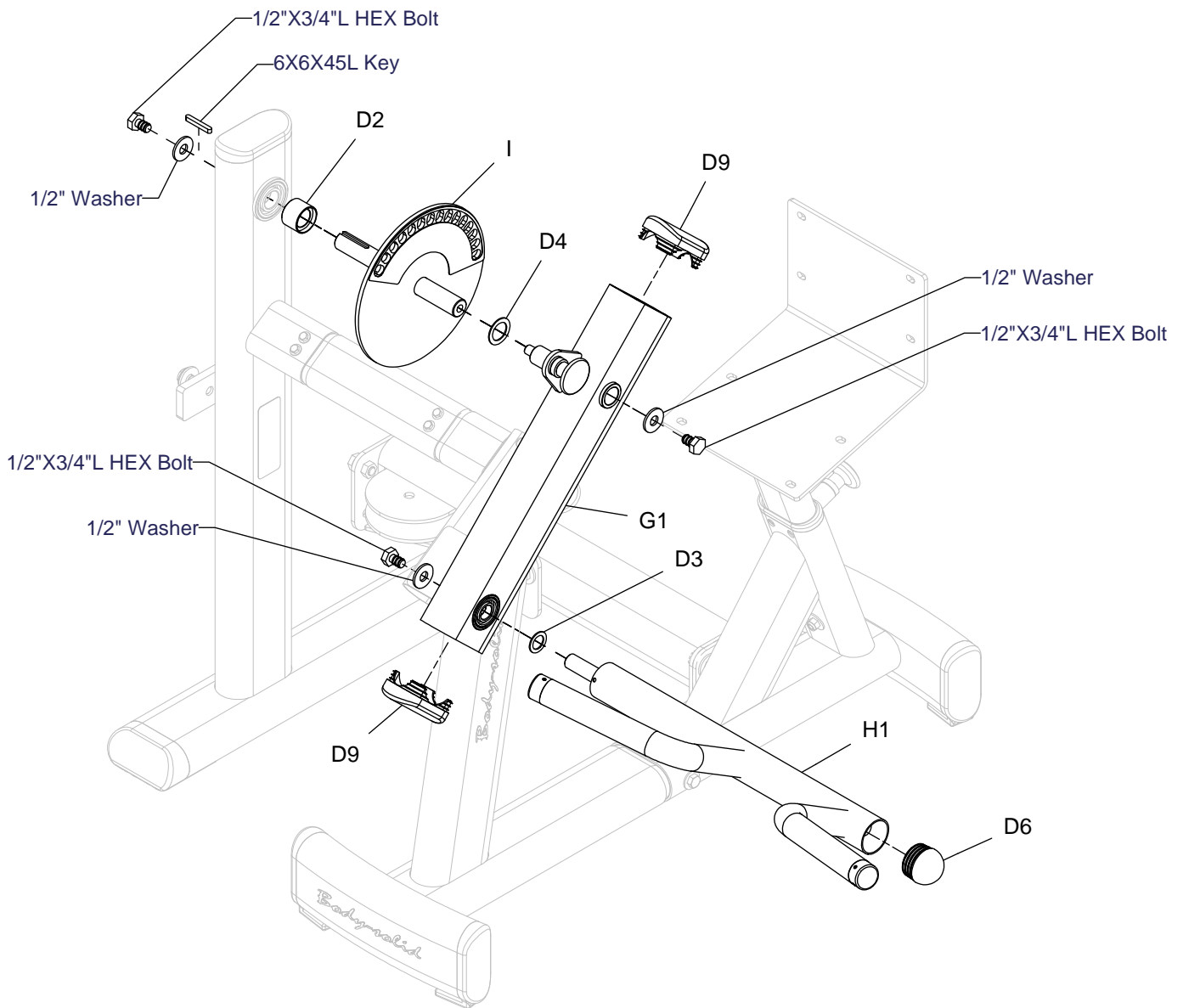

DBTC ASSEMBLY INSTRUCTIONS

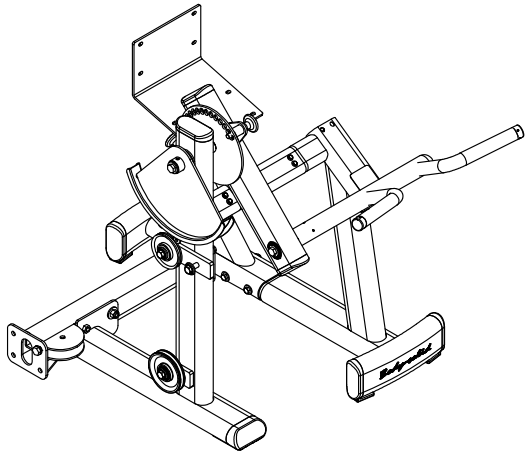

Above shows STEP 4 assembled and completed

Detail View

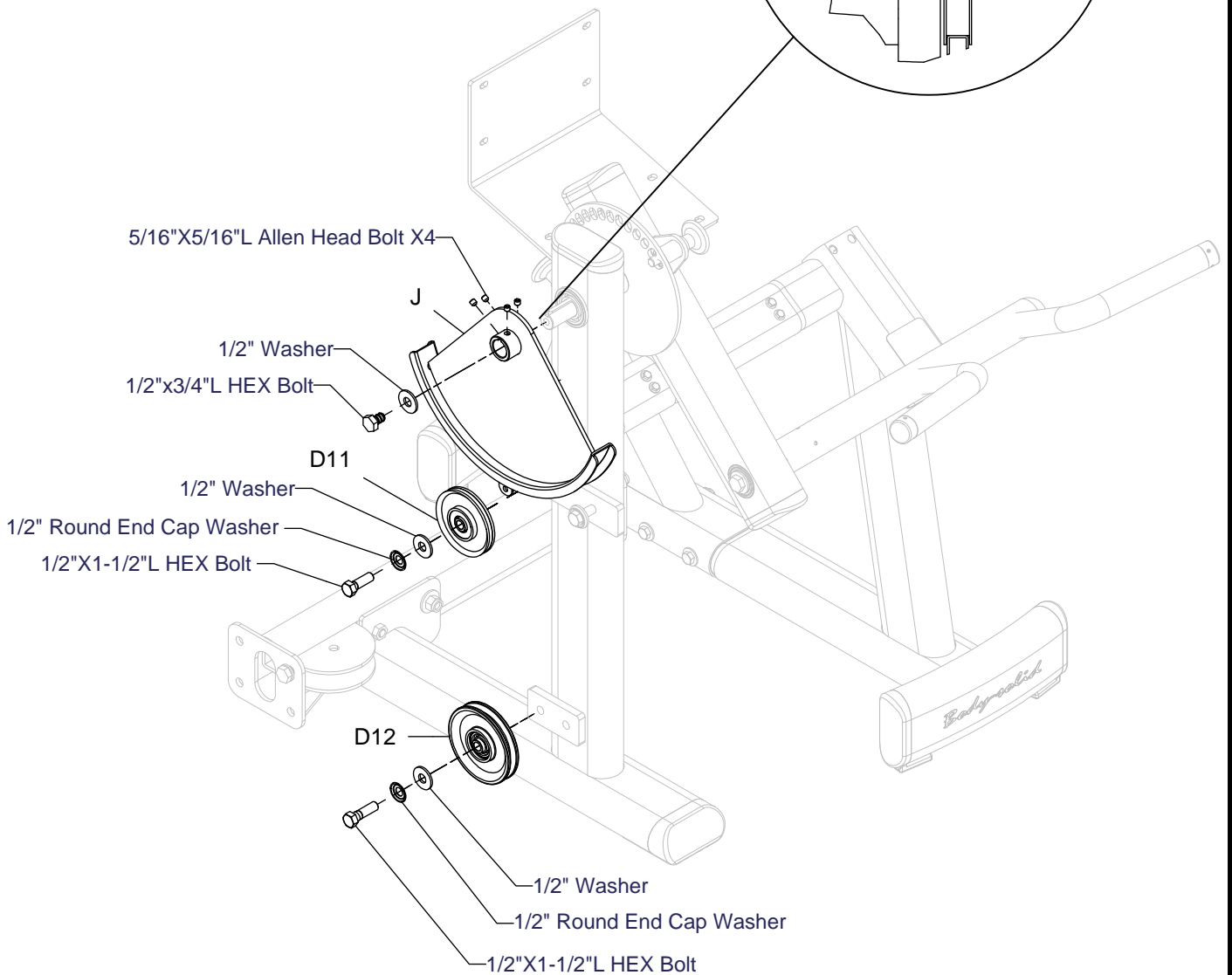
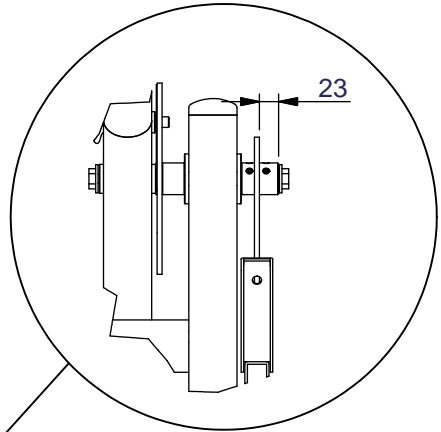

DBTC ASSEMBLY INSTRUCTIONS

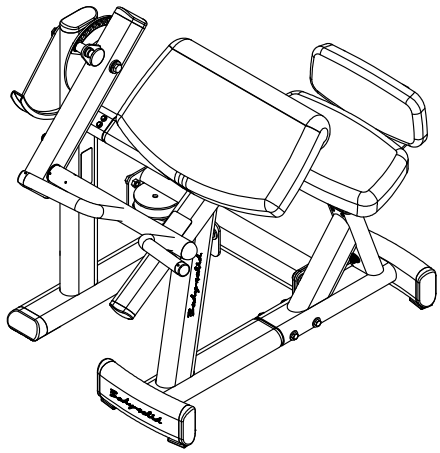

Above shows STEP 5
assembled and completed

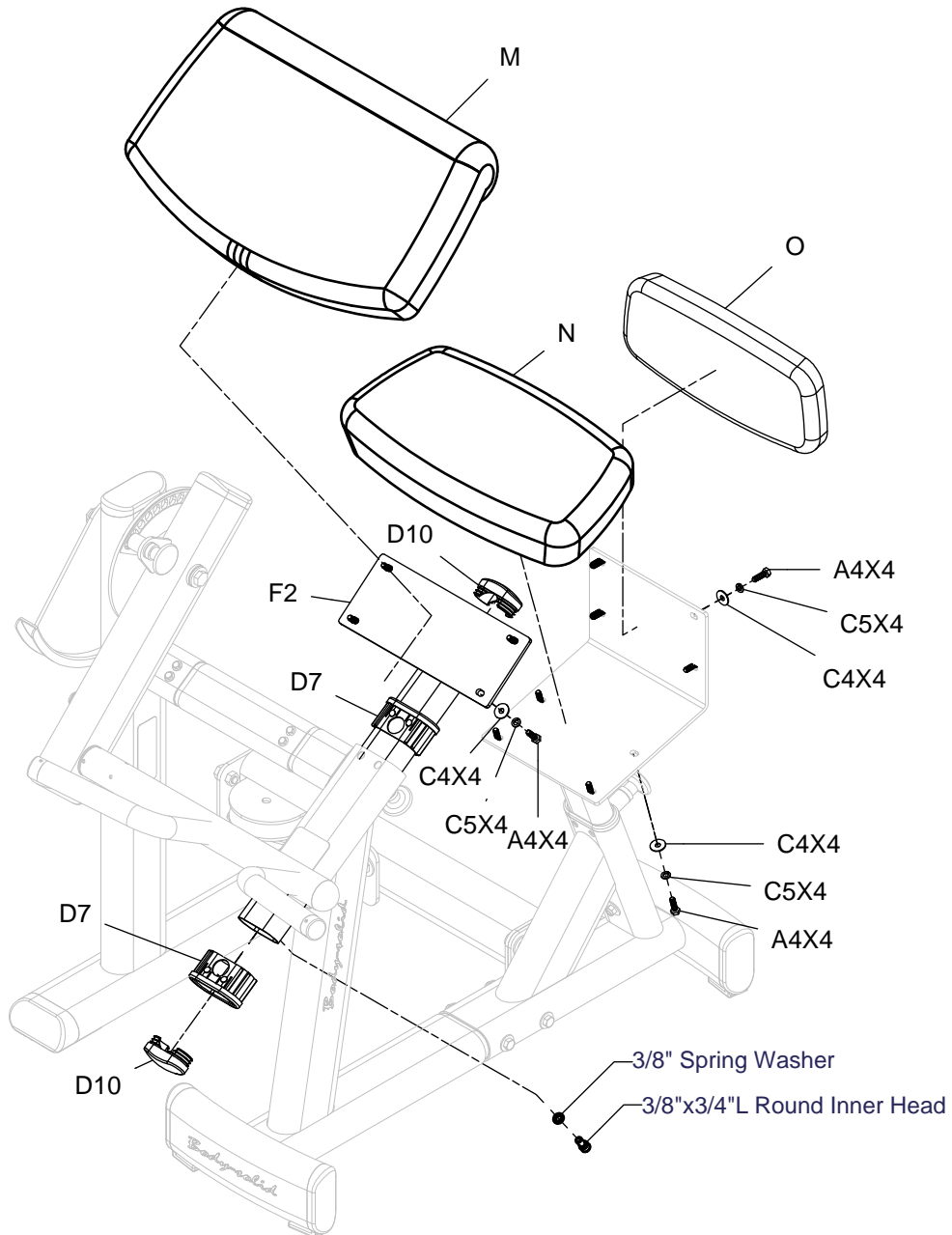

DBTC ASSEMBLY INSTRUCTIONS

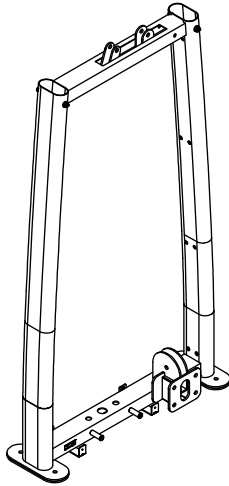

Above shows STEP 6
assembled and completed

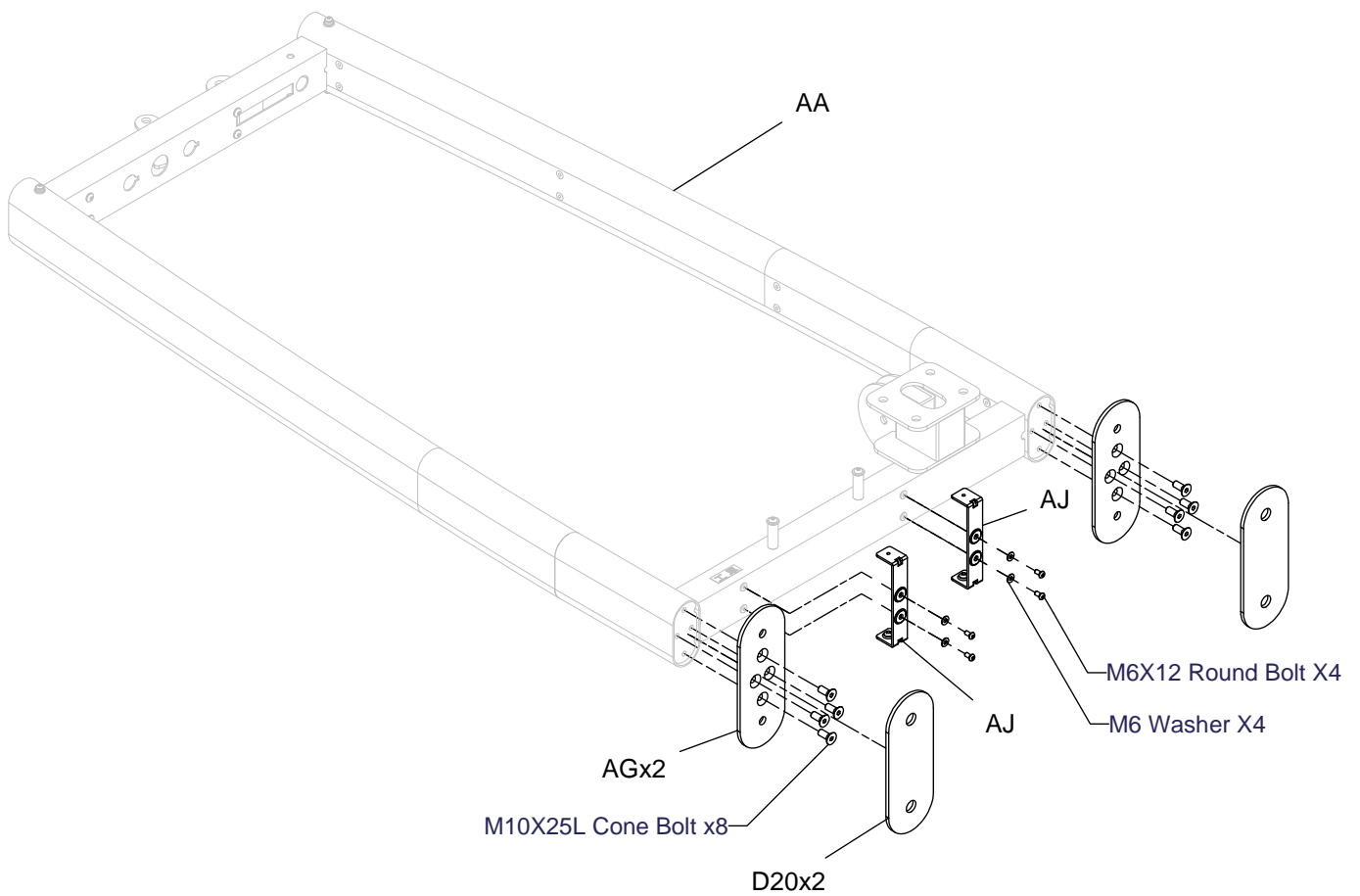

DBTC ASSEMBLY INSTRUCTIONS

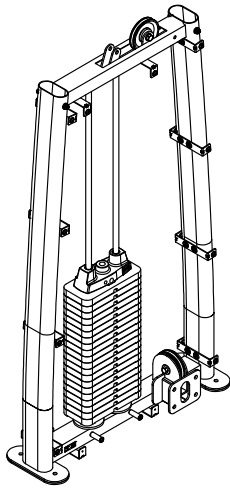

Above shows STEP 7
assembled and completed

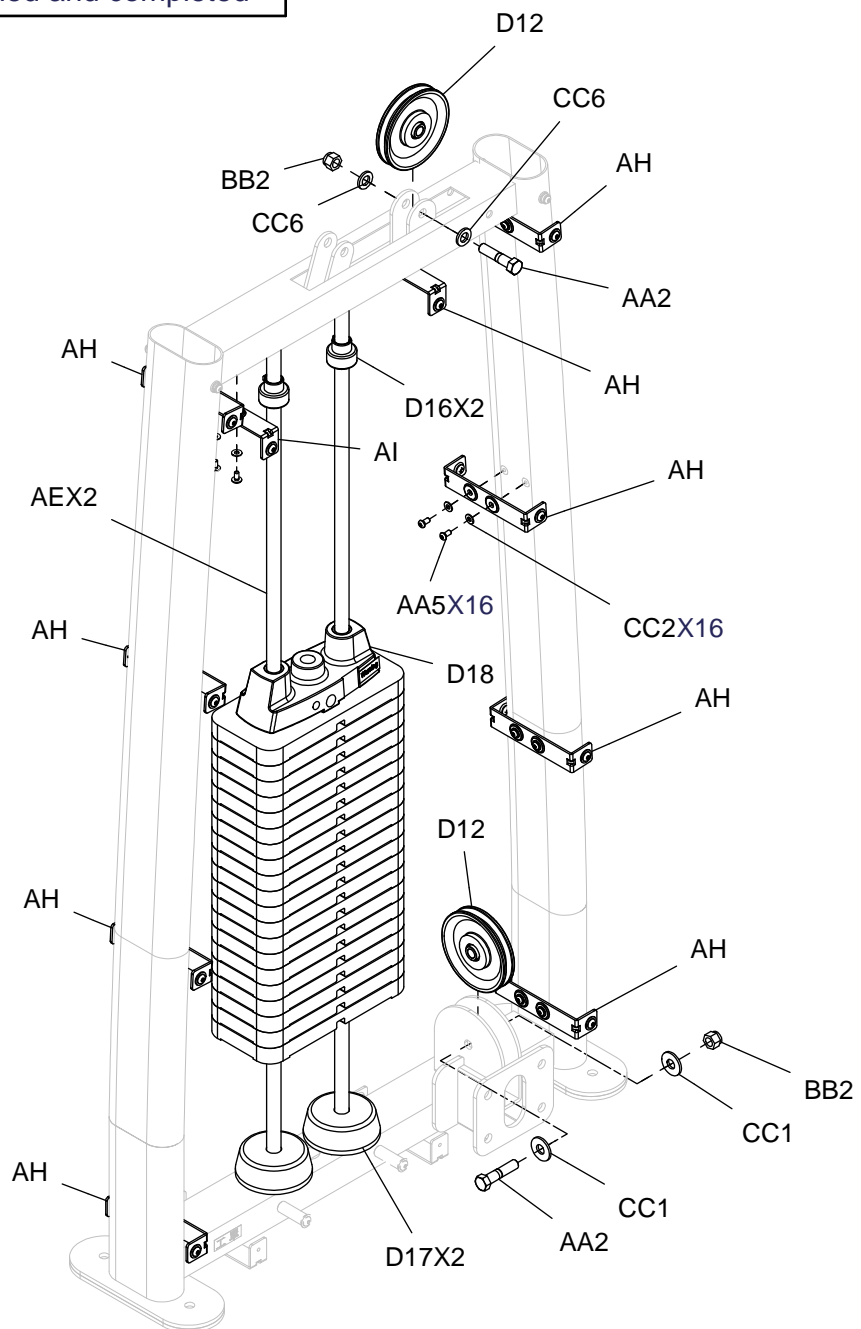

DBTC ASSEMBLY INSTRUCTIONS

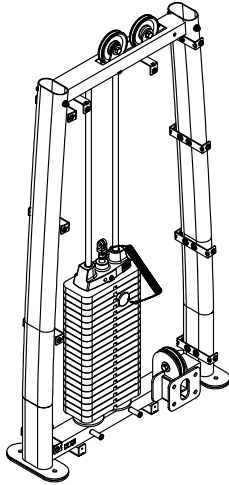

Above shows STEP 8
assembled and completed

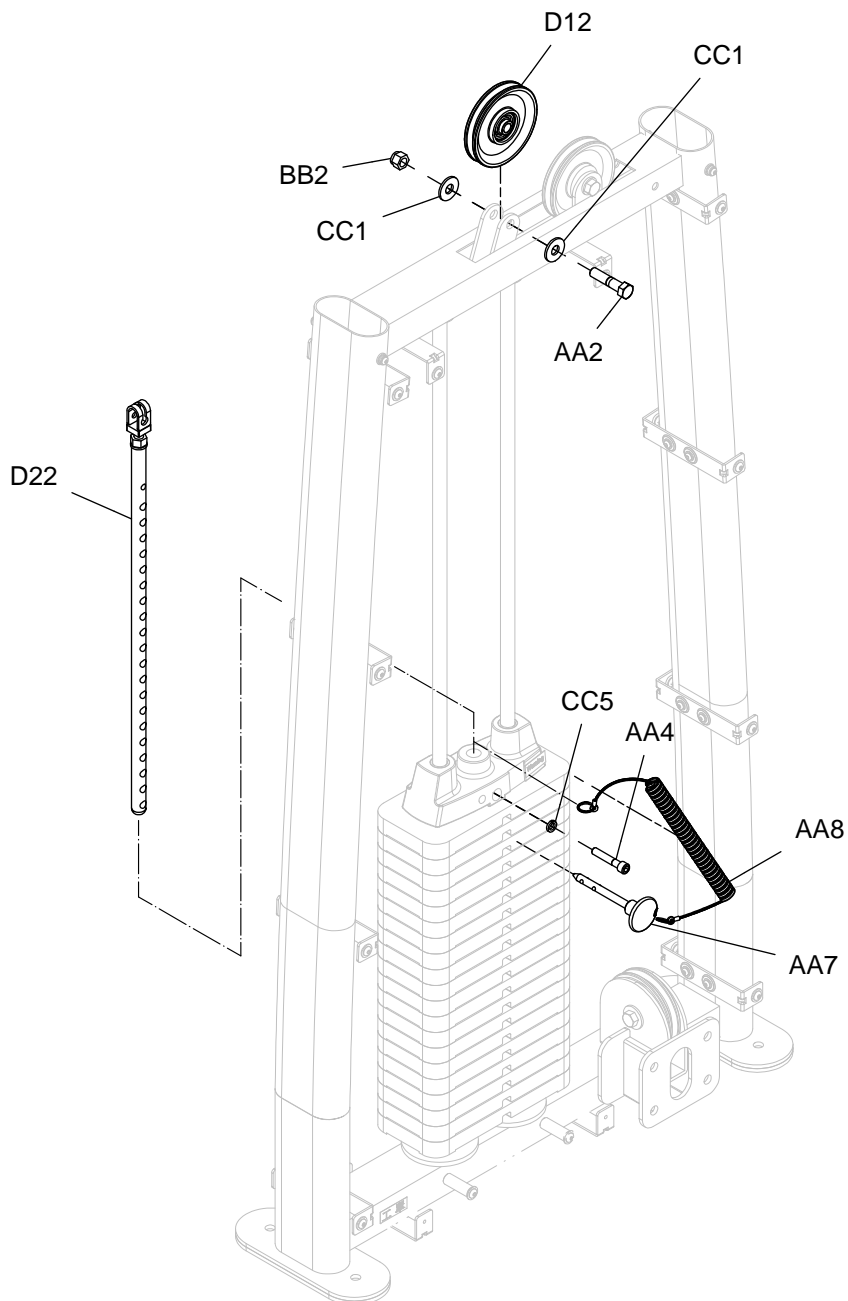

DBTC ASSEMBLY INSTRUCTIONS

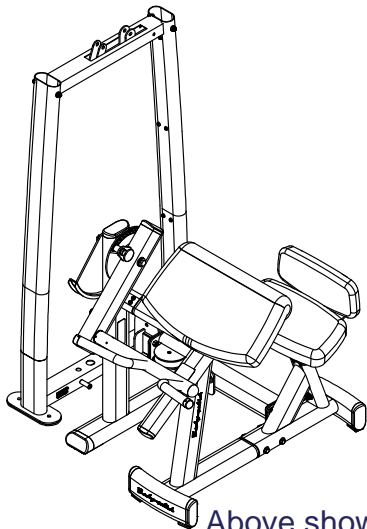

Above shows STEP 9 assembled and completed

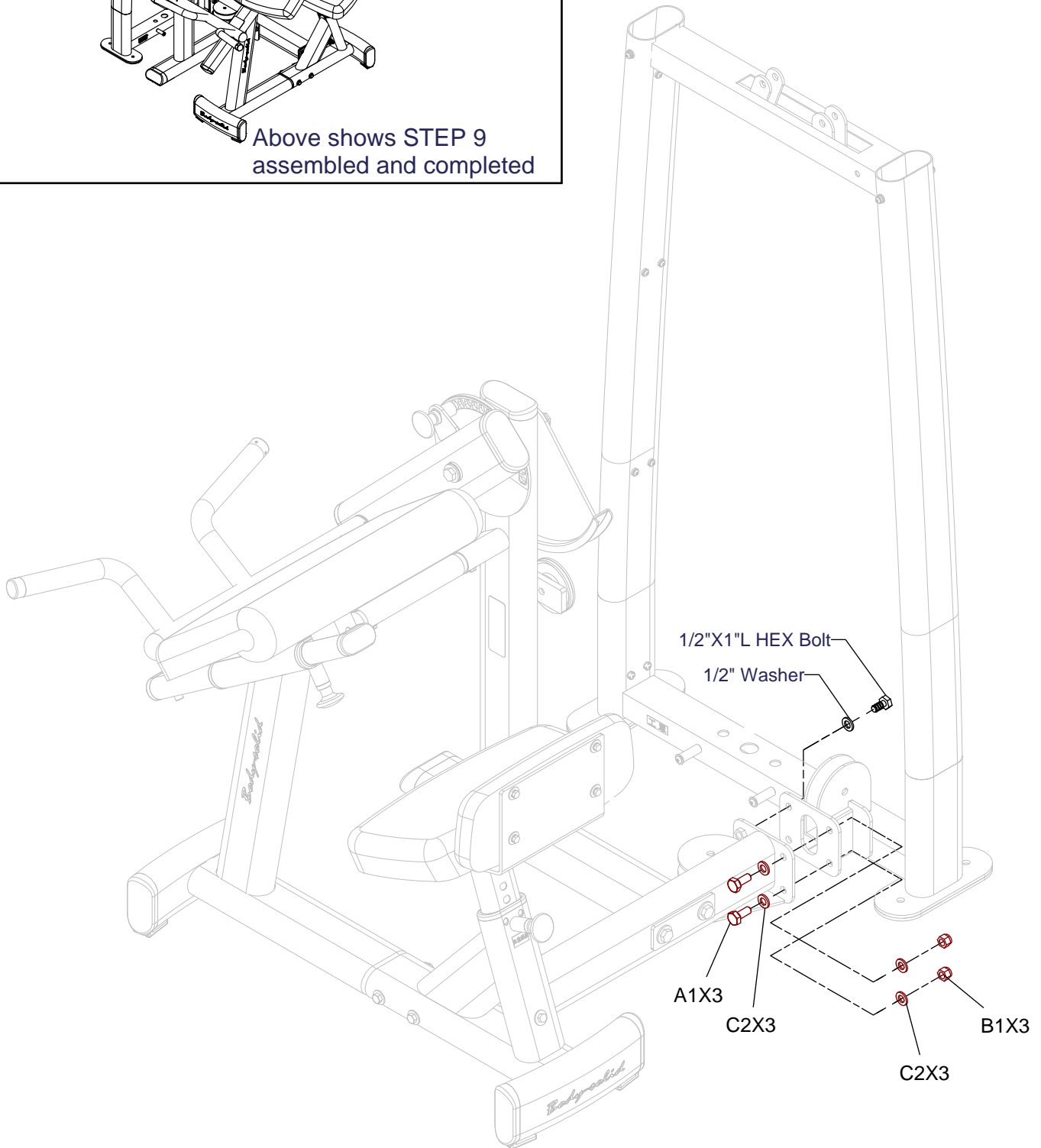

DBTC ASSEMBLY INSTRUCTIONS

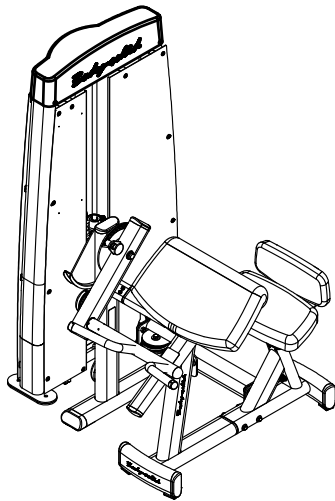

Above shows STEP 10 assembled and completed

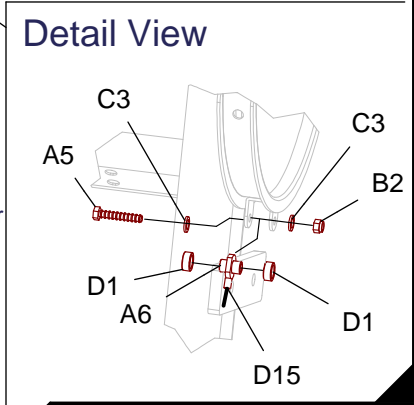
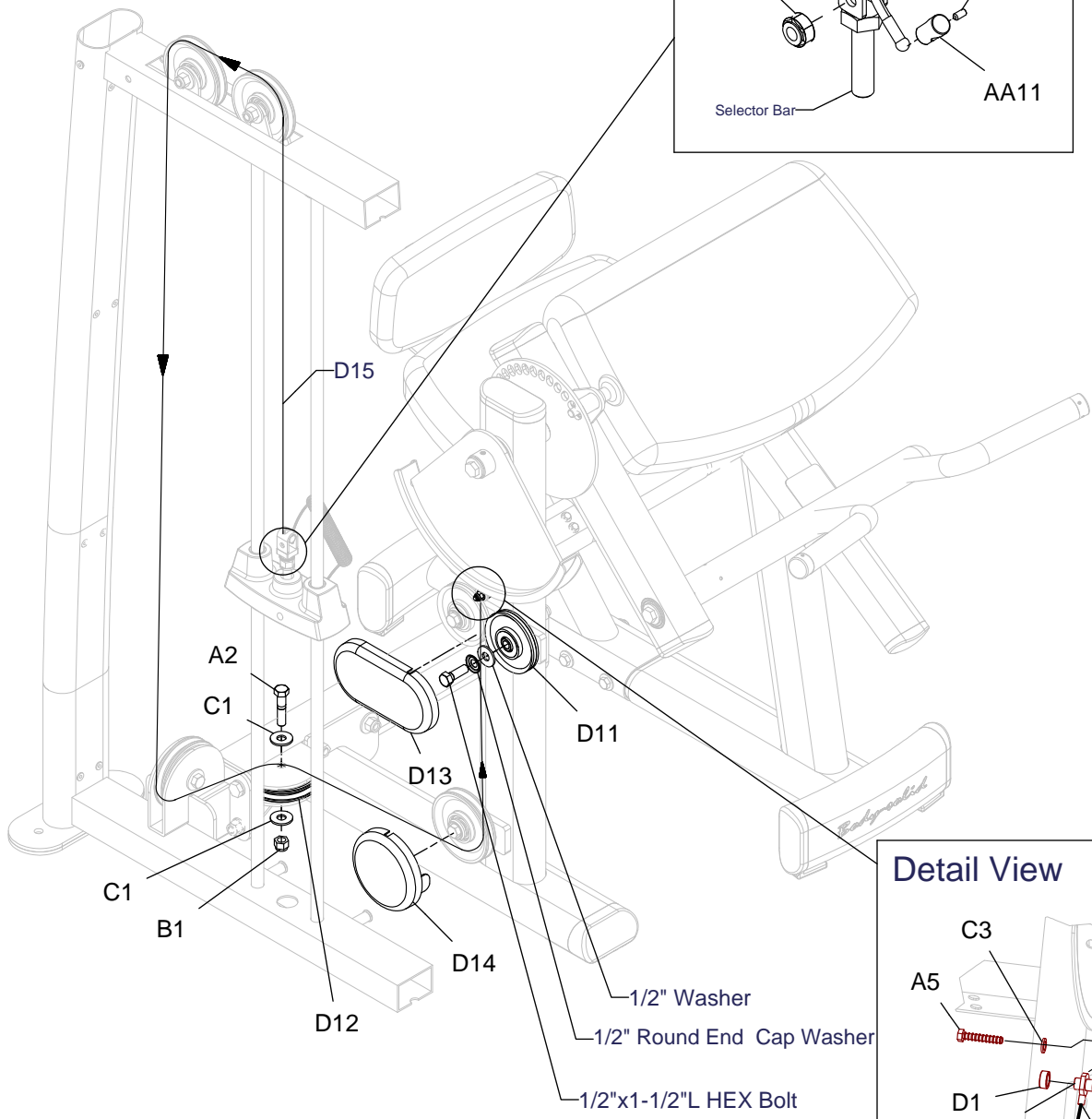
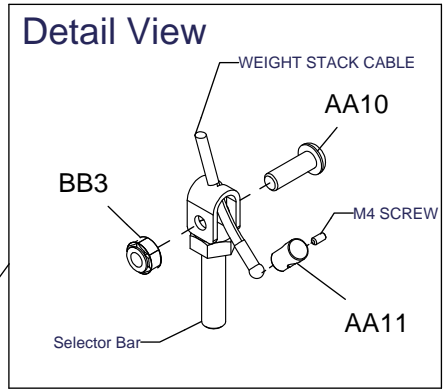

DBTC ASSEMBLY INSTRUCTIONS

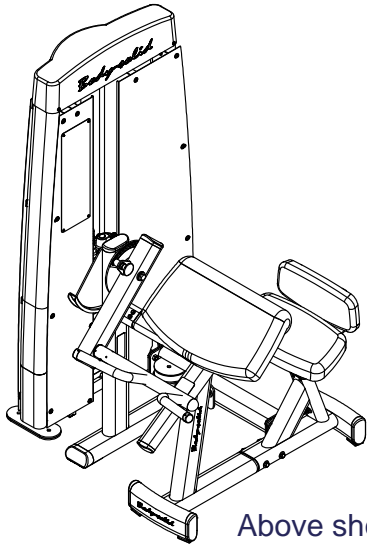

Above shows STEP 11
assembled and completed

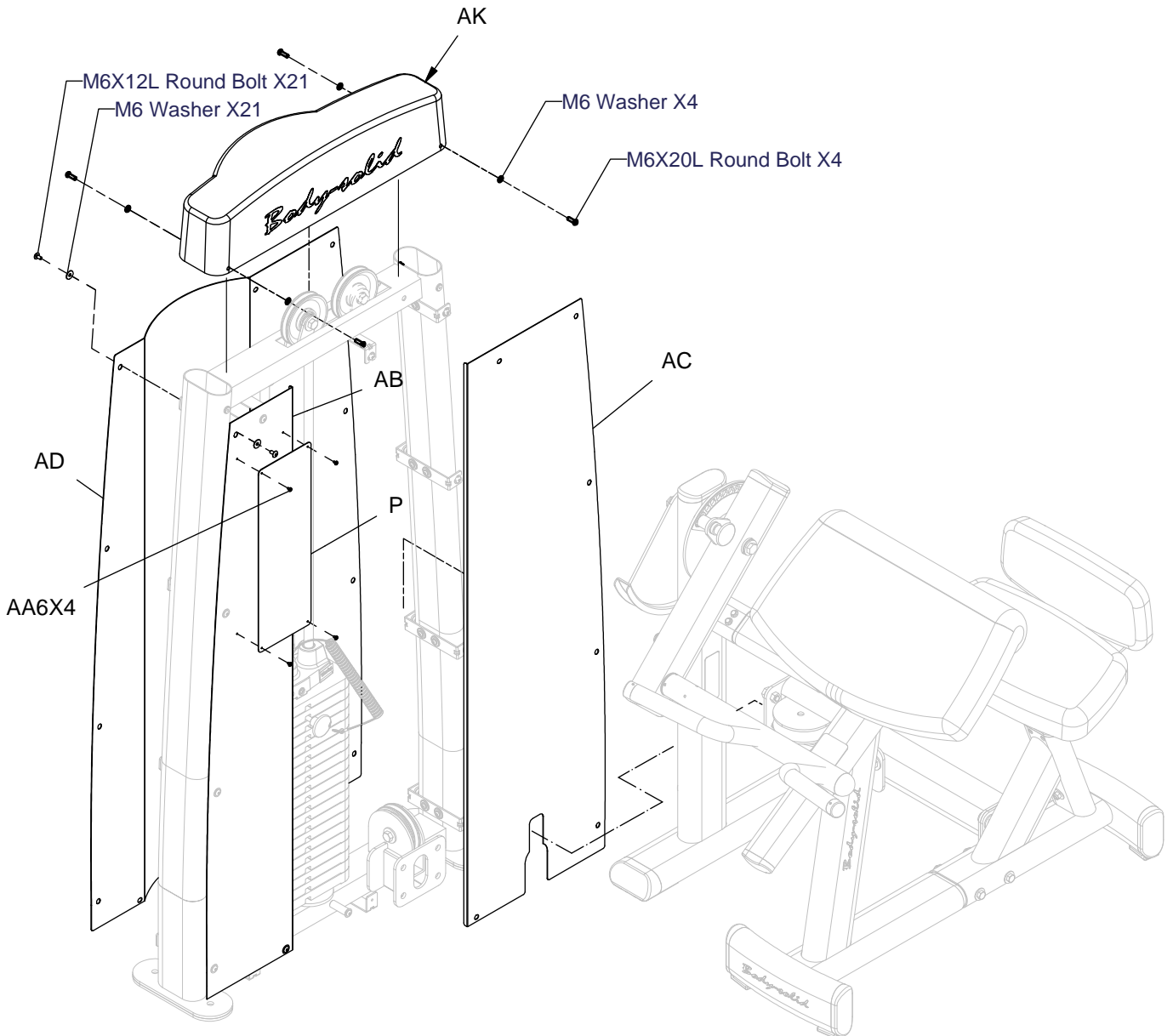

DBTC ASSEMBLY INSTRUCTIONS

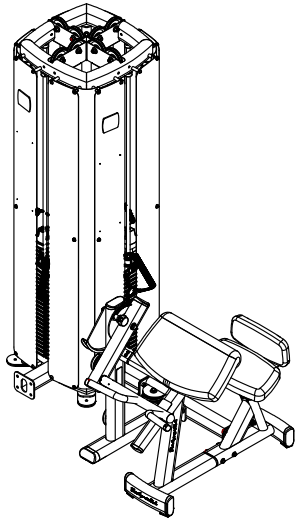

Above shows STEP 12
assembled and completed

D21.

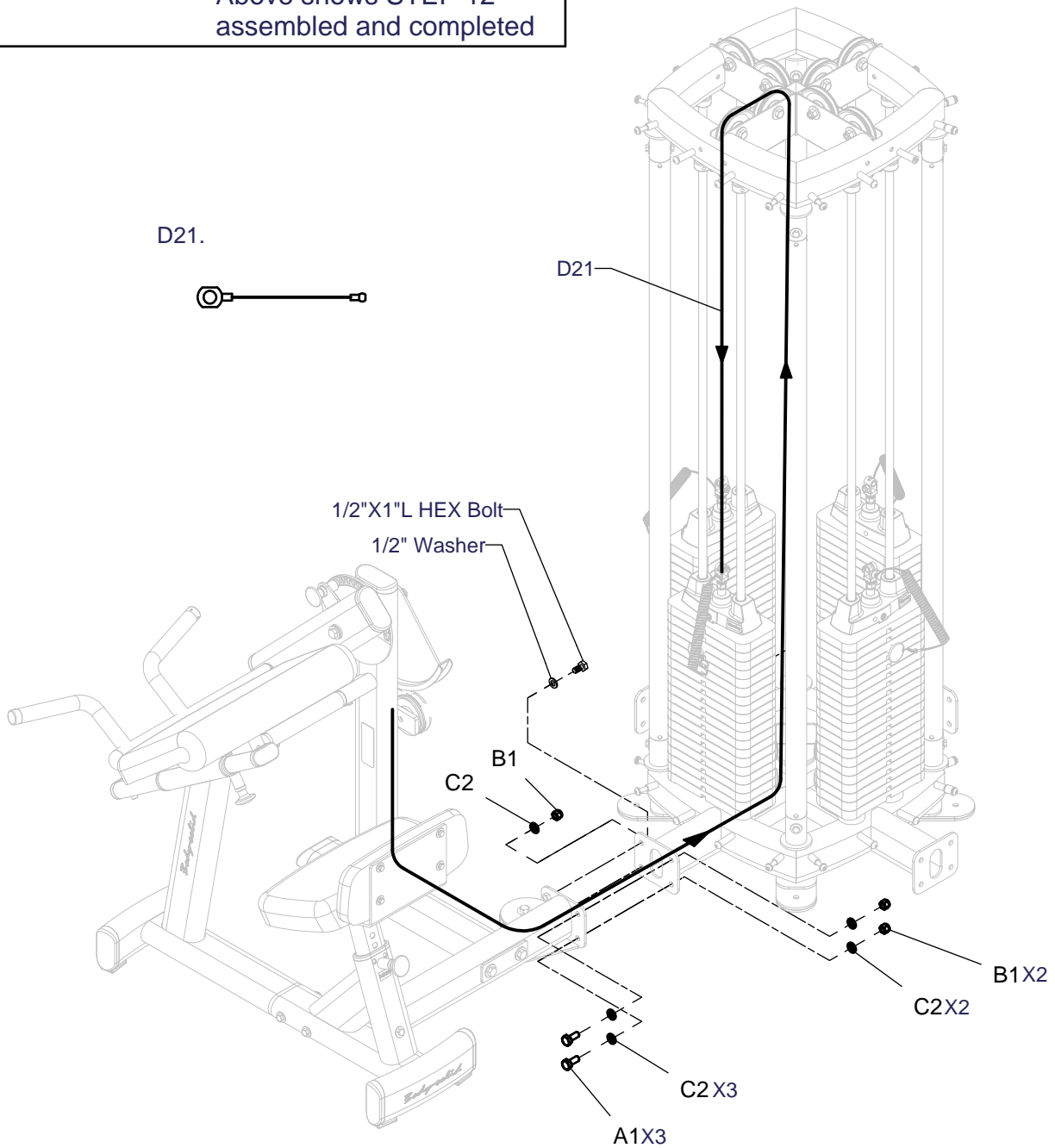

DBTC ASSEMBLY INSTRUCTIONS

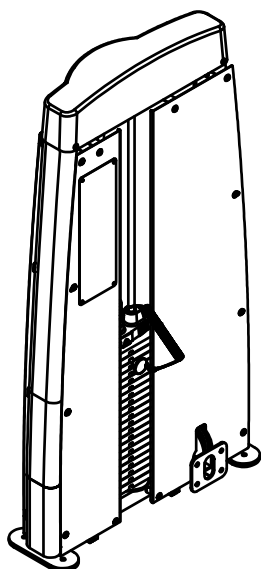
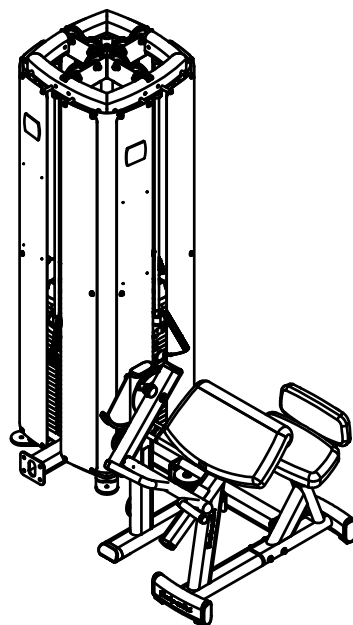
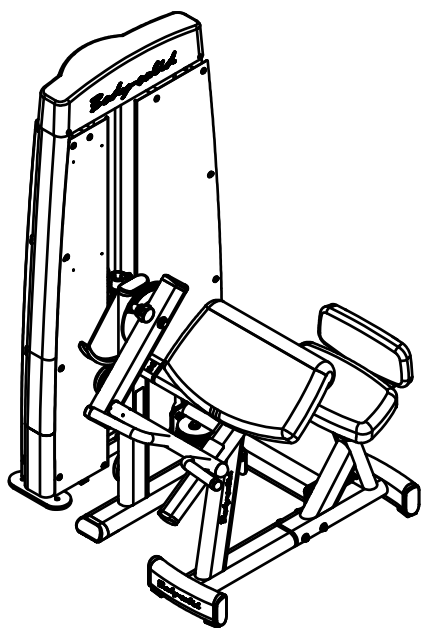

DFA

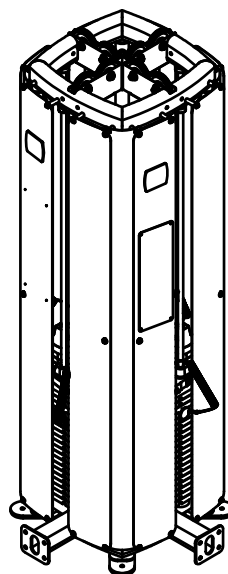

DGYM

DBTC

