

Body-Solid

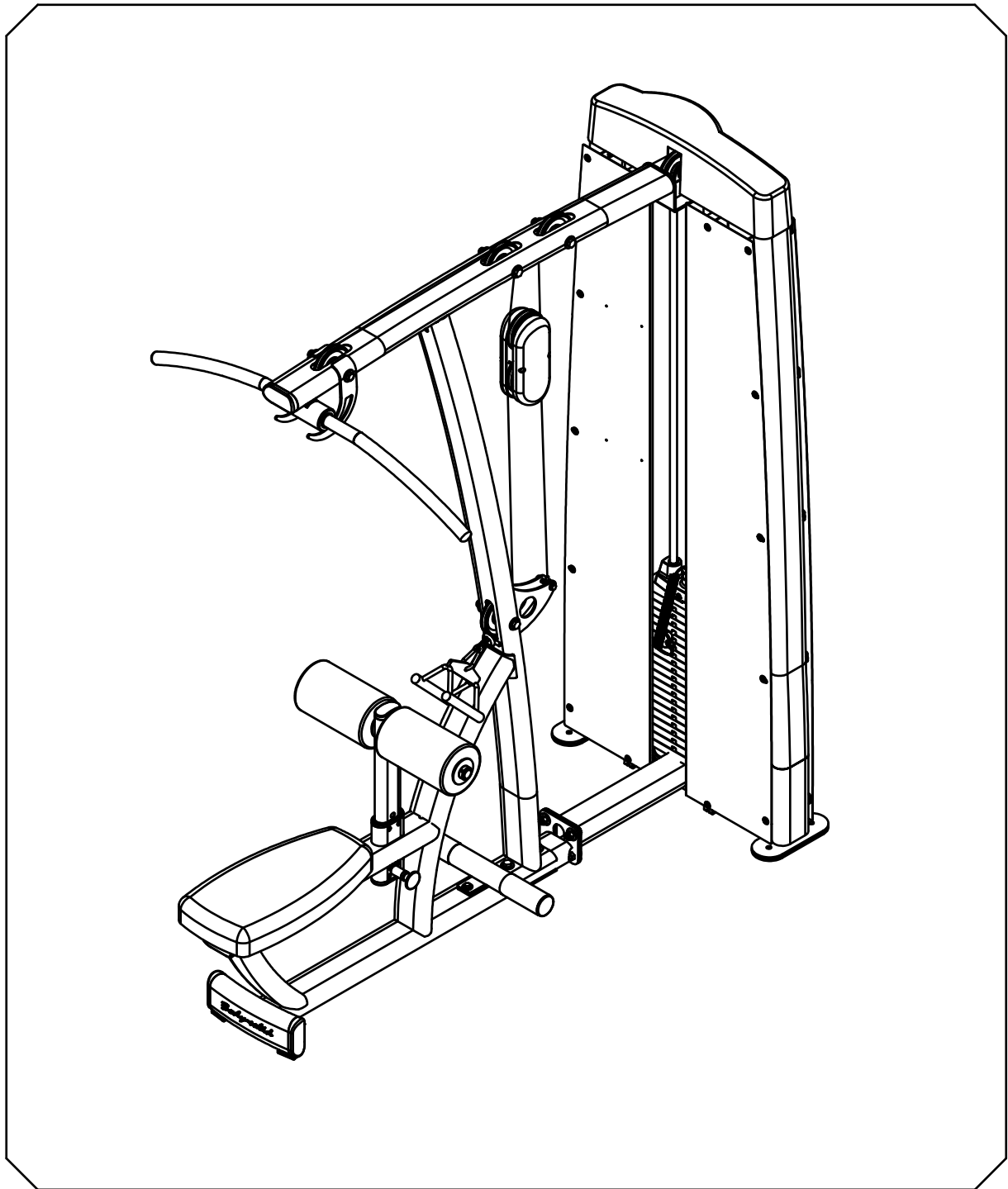

BODY-SOLID, Inc.
1900 S. Des Plaines Ave.
Forest Park, IL 60130 USA
Phone: (708) 427-3555
Fax: (708) 427-3556
www.bodysolid.com

DLAT.1 OWNER'S MANUAL

DLAT ASSEMBLY INSTRUCTIONS

HARDWARE ILLUSTRATION

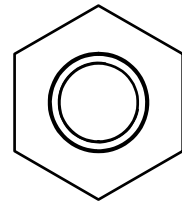
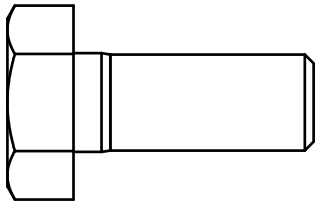

(A1)HEX BOLT 1/2"x1 1/4"L PARTIAL THREAD QTY.2

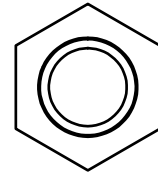
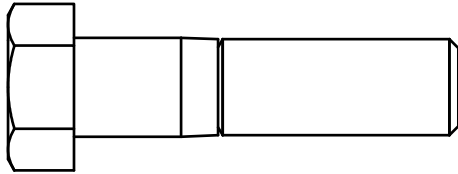

(A2)HEX BOLT 1/2"x2"L PARTIAL THREAD QTY.2

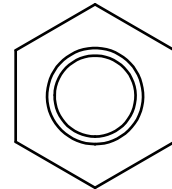
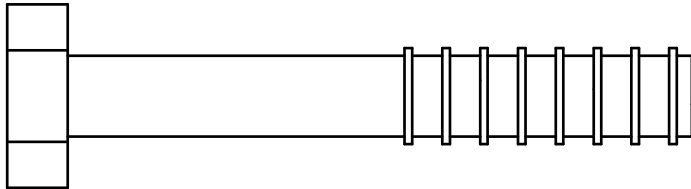

(A3)HEX BOLT 1/2"x3 1/4"L PARTIAL THREAD QTY.1

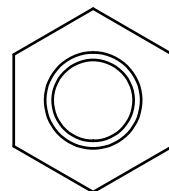
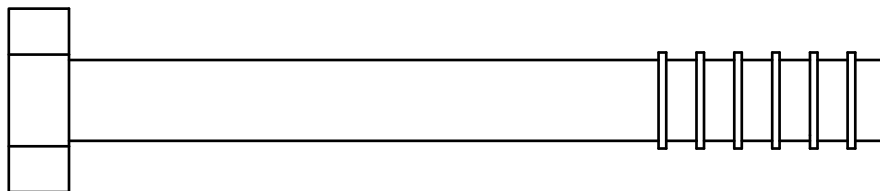

(A4)HEX BOLT 1/2"x4 1/4"L PARTIAL THREAD QTY.2

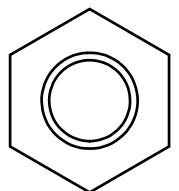
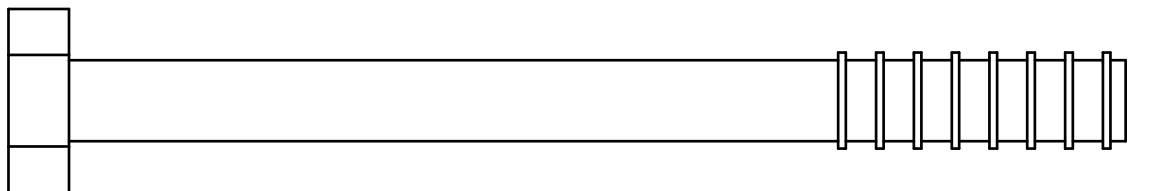

(A5)HEX BOLT 1/2"x5 1/2"L PARTIAL THREAD QTY.3

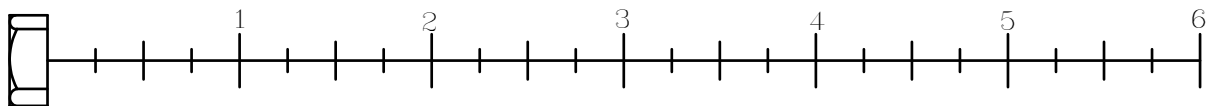

DLAT ASSEMBLY INSTRUCTIONS

HARDWARE ILLUSTRATION

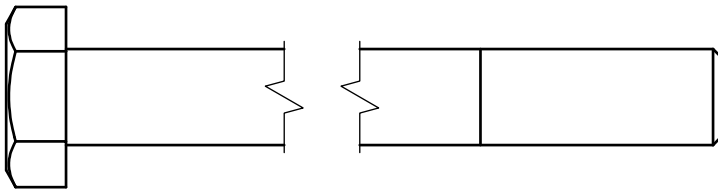

(A6)HEX BOLT 1/2"x5 3/4"L PARTIAL THREAD QTY.1

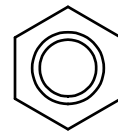
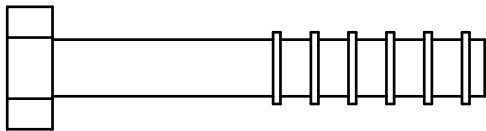

(A7)HEX BOLT 3/8"x2 1/4"L PARTIAL THREAD QTY.1

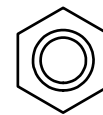
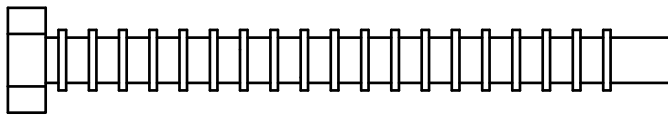

(A9)HEX BOLT 5/16"x3 1/4"L PARTIAL THREAD QTY.2

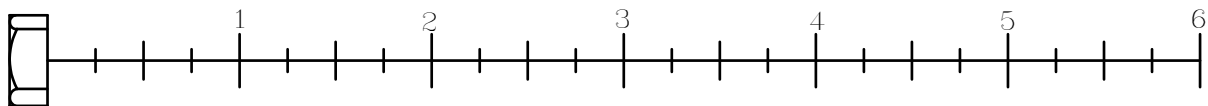

DLAT ASSEMBLY INSTRUCTIONS

HARDWARE ILLUSTRATION CONNECT DGYM

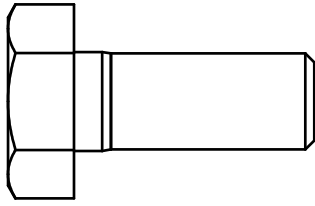

(A10)HEX BOLT 1/2"x1 1/4"L PARTIAL THREAD QTY.4

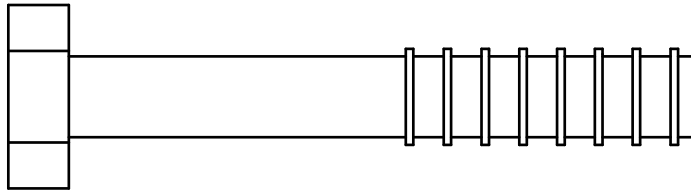
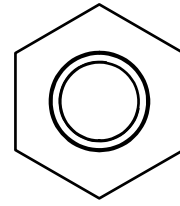

(A11)HEX BOLT 1/2"x3 1/4"L PARTIAL THREAD QTY.1

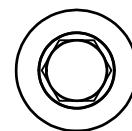
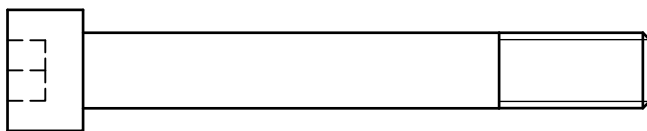
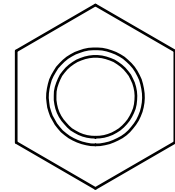

(A21)ROUND ALLEN HEAD M10X75L PARTIAL THREAD QTY.2

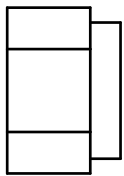

(B1)NYLON LOCK NUT 1/2" QTY.5

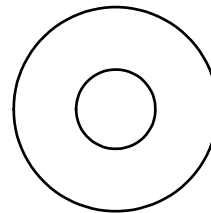
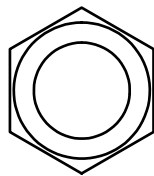

(C12)M10(I.D.)FLAT WASHER Ø27 QTY.2

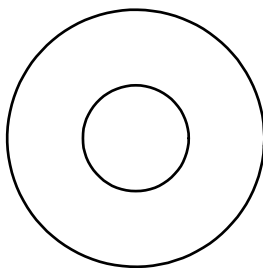

(C1)1/2"(I.D.)FLAT WASHER Ø34 QTY.10

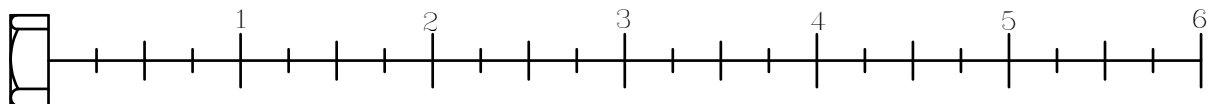

DLAT ASSEMBLY INSTRUCTIONS

FRAME HARDWARE ILLUSTRATION

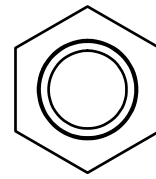
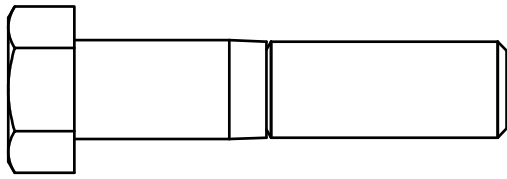

(A13)HEX BOLT 1/2"x2 1/4"L PARTIAL THREAD QTY.1

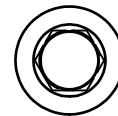
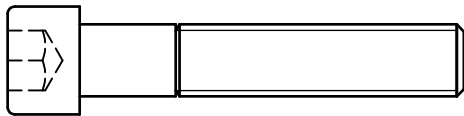

(A15)ROUND ALLEN HEAD 3/8"X2"L PARTIAL THREAD QTY.1

Optional Purchase

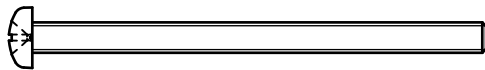

(A14)HEX BOLT M4X65L"L PARTIAL THREAD QTY.2

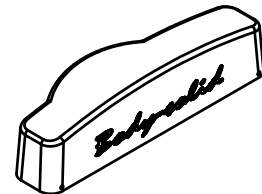

TOP CAP(9211-111)

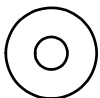

(C10)M4(I.D.)FLAT WASHER Ø12 QTY.2

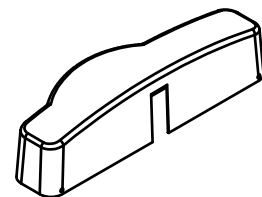

TOP CAP(9211-119)

"M4X65 ROUND BOLT" and "M4 WASHER" is used to assemble with 9211-111 and 9211-119 TOP CAP

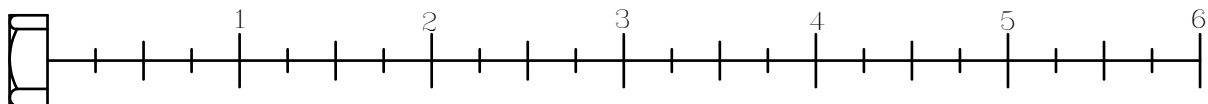

DLAT ASSEMBLY INSTRUCTIONS

FRAME HARDWARE ILLUSTRATION

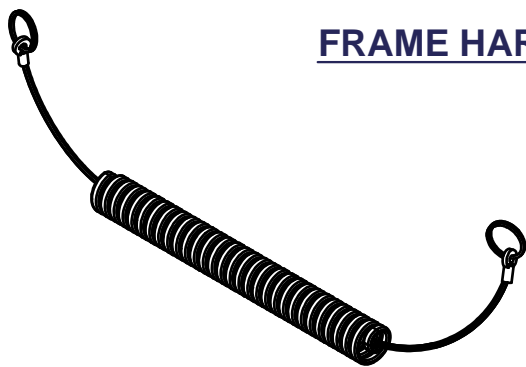

(A16)ELASTIC BOLT QTY.1

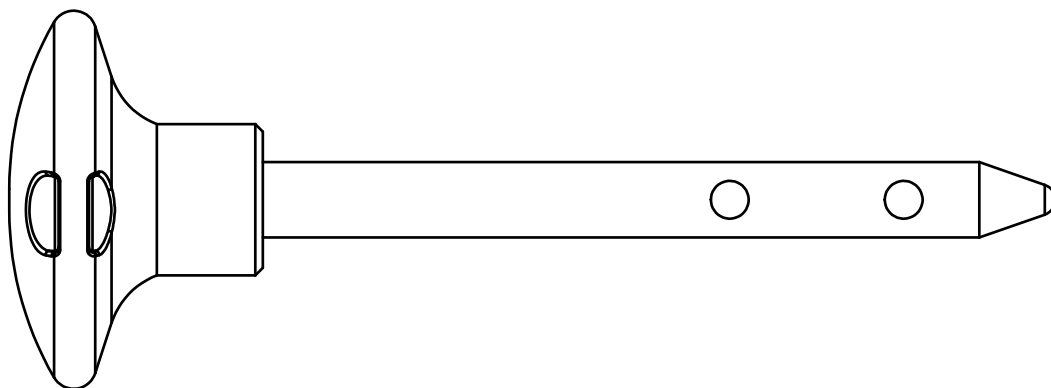

(A17)10LB PIN (8250-071) QTY.1



(A19)ROUND ALLEN HEAD M6X20L PARTIAL THREAD QTY.24



(A20)ROUND ALLEN HEAD 5/32"X1/4"L PARTIAL THREAD QTY.4

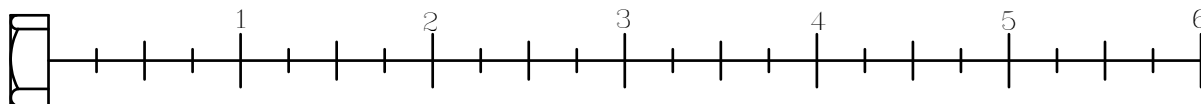

DLAT ASSEMBLY INSTRUCTIONS

HARDWARE ILLUSTRATION

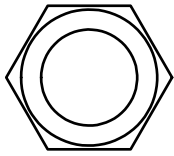

(B2) NYLON LOCK NUT 1/2" QTY. 10

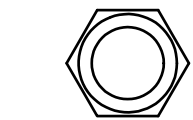
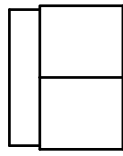

(B3) NYLON LOCK NUT 3/8" QTY. 1

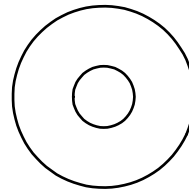
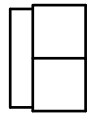

(C5) 5/16" (I.D.) FLAT WASHER Ø24 QTY. 2

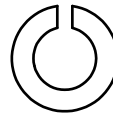

(C6) 5/16" SPRING WASHER QTY. 2

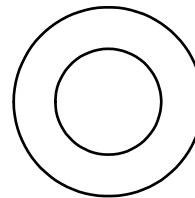

(C13) 1/2" (I.D.) FLAT WASHER Ø25 QTY. 4

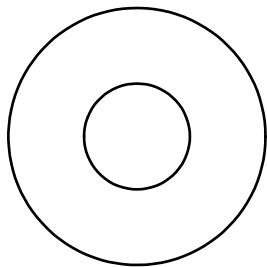

(C3) 1/2" (I.D.) FLAT WASHER Ø34 QTY. 17

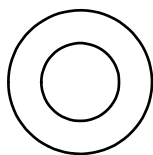
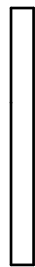

(C4) 3/8" (I.D.) FLAT WASHER Ø19 QTY. 2



DLAT ASSEMBLY INSTRUCTIONS

FRAME HARDWARE ILLUSTRATION

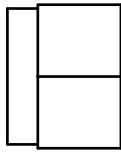
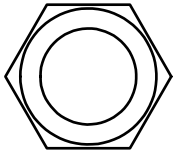

(B5)NYLON LOCK NUT 1/2" QTY.1

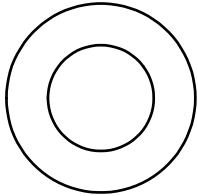

(C8)1/2"(I.D.)FLAT WASHER \varnothing 25 QTY.2

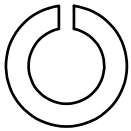

(C9)3/8" SPRING WASHER QTY.1

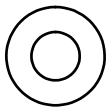

(C11)M6(I.D.)FLAT WASHER \varnothing 13 QTY.24

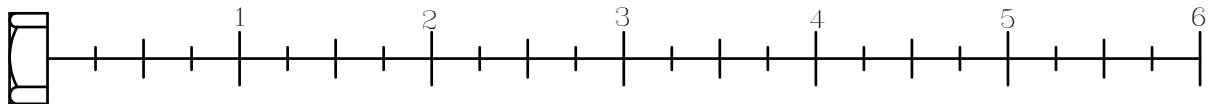

DLAT ASSEMBLY INSTRUCTIONS

Selector Rod HARDWARE ILLUSTRATION

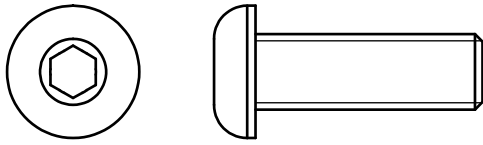

(A22)ROUND ALLEN HEAD M10X30L PARTIAL THREAD QTY.1

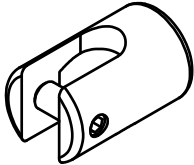

(A23)FIRM SHEATH(8890-046) QTY.1

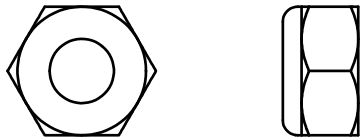

(B6)NYLON LOCK NUT M10 QTY.1

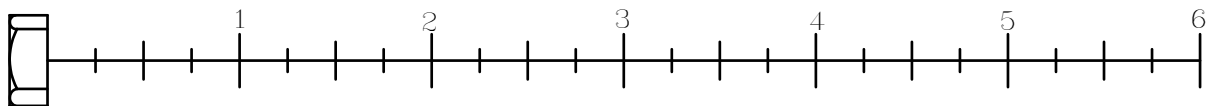

DLAT ASSEMBLY INSTRUCTIONS

HARDWARE ILLUSTRATION

D1.Ø3/4"X16L STEEL BUSHING (8110-066)	[2PCS]
D2.Ø3/4"X45L STEEL BUSHING (8110-067)	[8PCS]
D3.Ø1" SHAFT COLLAR(8130-024)	[2PCS]
D4.Ø8 SPRING SNAP LINK(8810-001)	[2PCS]
D5.Ø1" END CAP(9211-016)	[2PCS]
D6.Ø60 END CAP(9211-065)	[2PCS]
D7.50X100(40X80)NYLON BUSHING(9211-107)	[2PCS]
D8.58X116X2.5T FOOT CAP(9211-108)	[2PCS]
D9.COVER(9211-110)	[2PCS]
D10.58X116 END CAP(9211-112)	[2PCS]
D11.40X80 END CAP(9211-113)	[2PCS]
D12. 3" Nylon Washer (9214-008)	[4PCS]
D13. Ø1"x2.5t Round End Cap(9260-021)	[2PCS]
D14.Ø3/4" SHAFT COLLAR(9211-046)	[2PCS]
D15.Ø2 1/2"X19.2X19.4T RUBBER DOUNT(9310-010)	[2PCS]
D16.95X140L RUBBER PAD(9310-035)	[2PCS]
D17.95X250 RUBBER PAD(9310-060)	[2PCS]

D1



D2

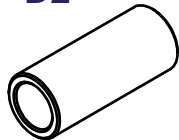

D3



D4



D5

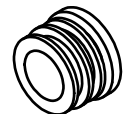

D6

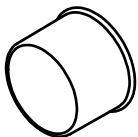

D7

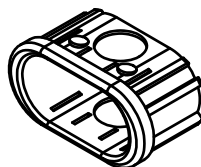

D8

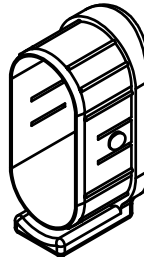

D9

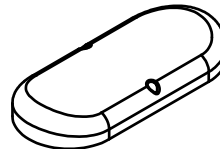

D10

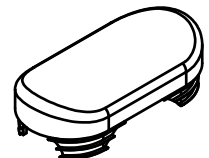

D11

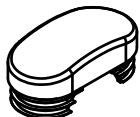

D12



D13

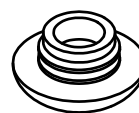

D14



D15

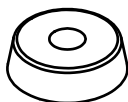

D16

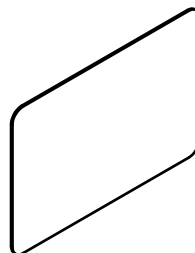

D17

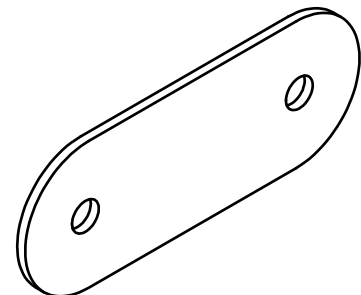

DLAT ASSEMBLY INSTRUCTIONS

HARDWARE ILLUSTRATION

D18.Ø117 PULLEY(9213-010B)-----	[8PCS]
D19.TOP PLATE(8400-006)-----	[1PCS]
D21.1975mm STEEEL CABLE(FDLATA)-----	[1PCS]
D22.3250mm STEEL CABLE(FDLATB)-----	[1PCS]
D23.DLAT For DGYM Steel Cable(FDLATC)-----	[1PCS]
D24.150X250L RUBBER PAD(9310-036)-----	[1PCS]
D25.WEIGHT SELECTOR BAR(8210-042B)-----	[1PCS]

D18

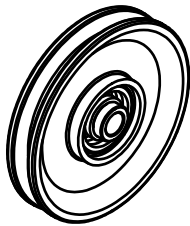

D19

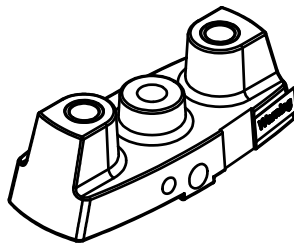

D21

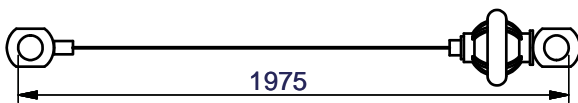

D22

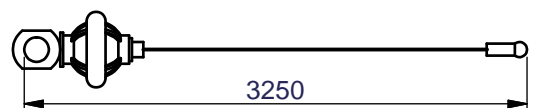

D24

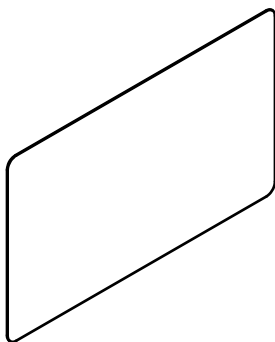

D25

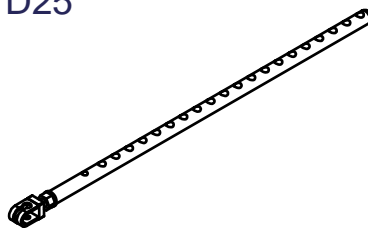

DLAT ASSEMBLY INSTRUCTIONS

PARTS ILLUSTRATION SHEET

A1[1PCS]

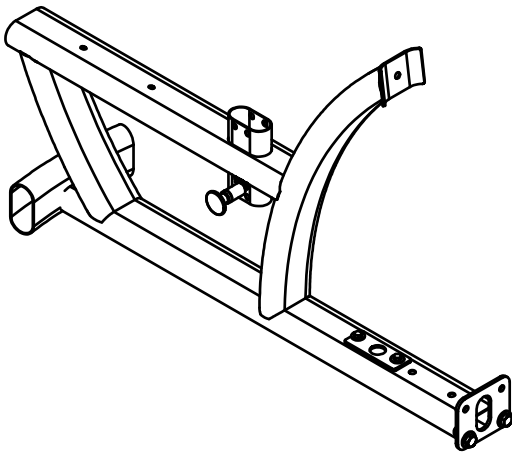

B[1PCS]

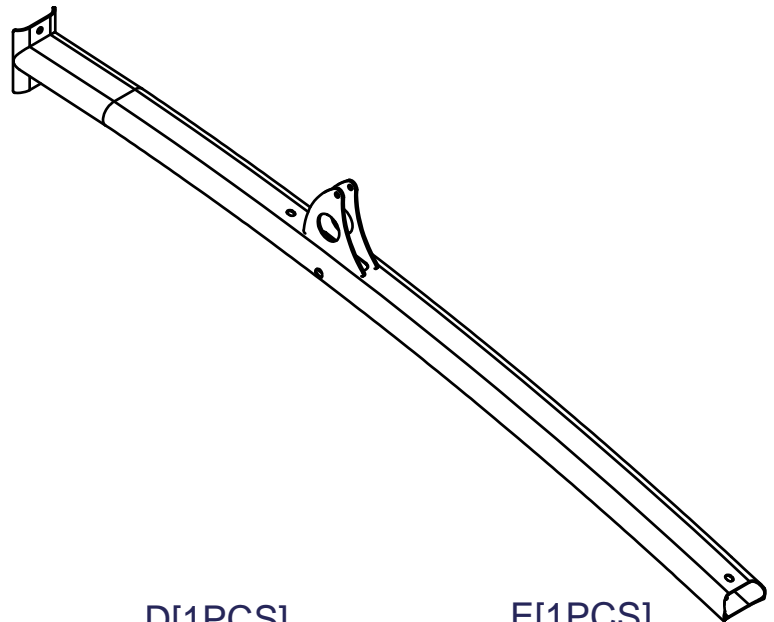

C[1PCS]

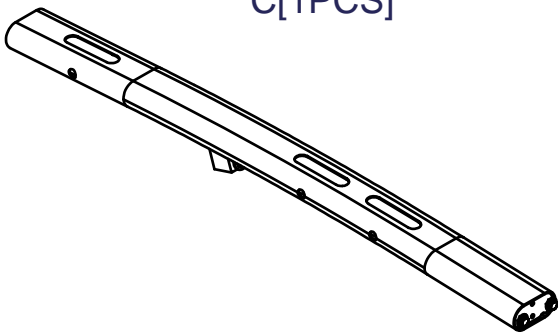

D[1PCS]

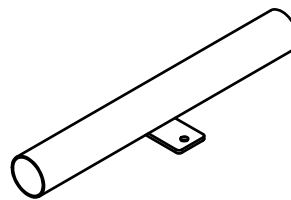

E[1PCS]

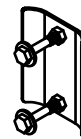

F[1PCS]

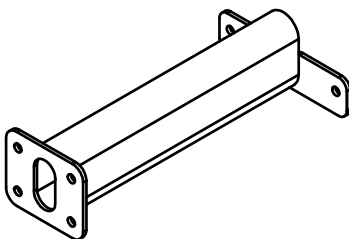

G[1PCS]
CONNECT DGM

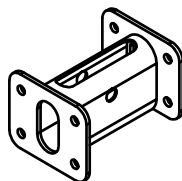

H[2PCS]

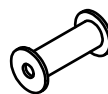

I[1PCS]

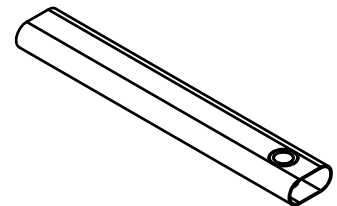

J[1PCS]
Ø1"X600L

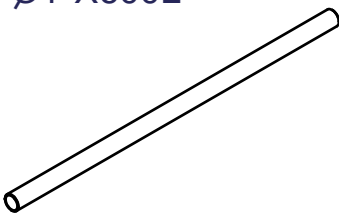

K[1PCS]
20LB1200D

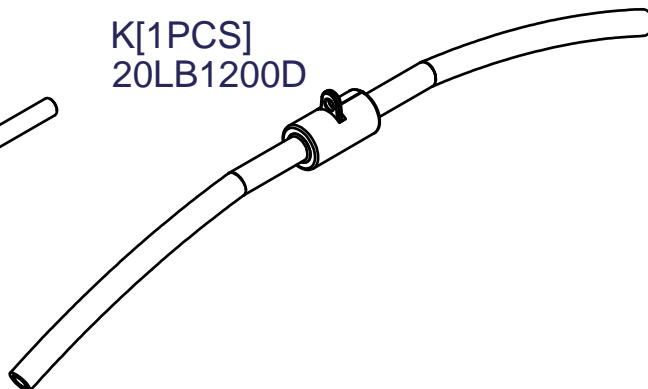

L[1PCS]
8313-130

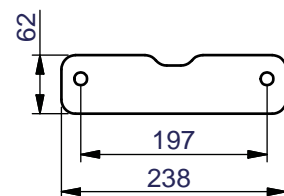

DLAT ASSEMBLY INSTRUCTIONS

PARTS ILLUSTRATION SHEET

M[1PCS]
8343-146

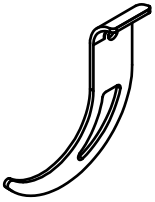

N[1PCS]
8343-147



O[2PCS]
8343-140

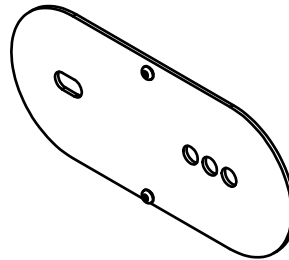

P[1PCS]
8290-001

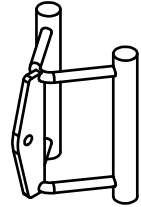

Q[1PCS]
9121-054

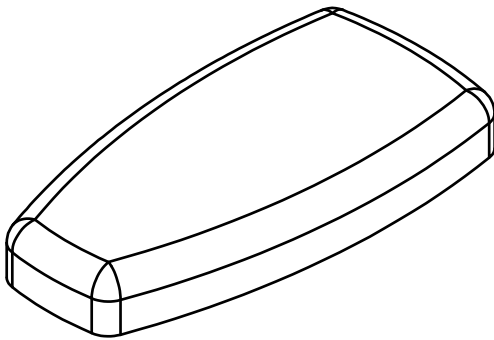

R[2PCS]
9161-021B
Ø150X250L

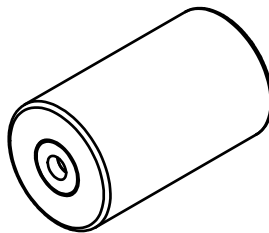

DLAT ASSEMBLY INSTRUCTIONS

FRAME PARTS ILLUSTRATION SHEET

S[1PCS]
6610-001

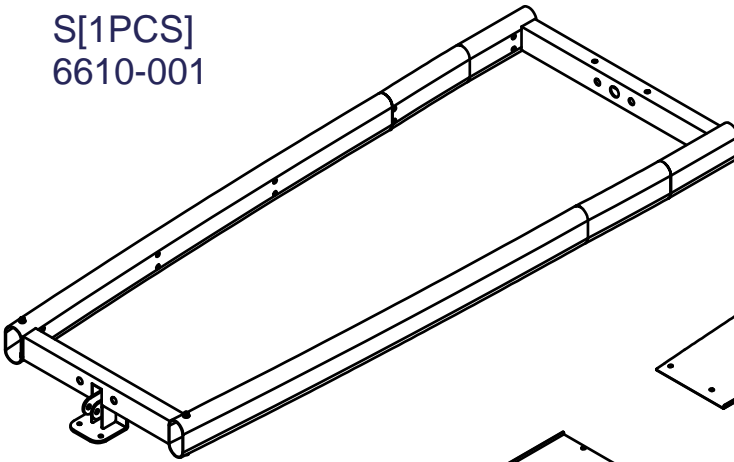

T[1PCS]
8380-044

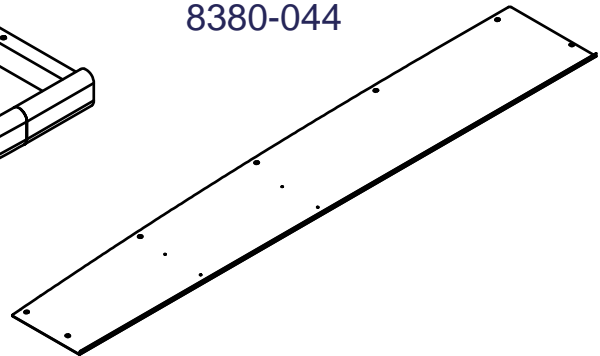

U[1PCS]
8380-052

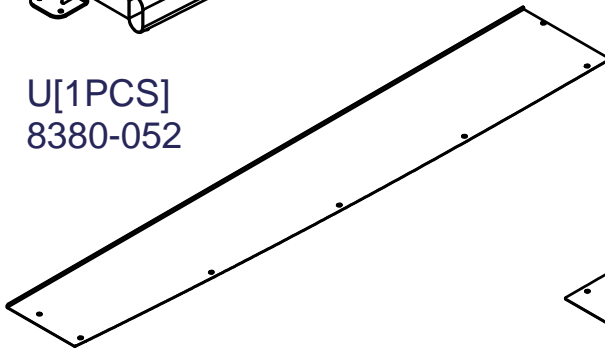

V[1PCS]
8380-045

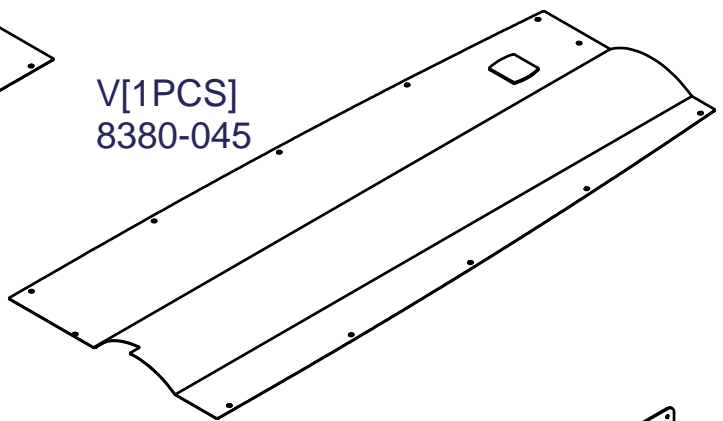

W[2PCS]
Ø3/4"X1932L

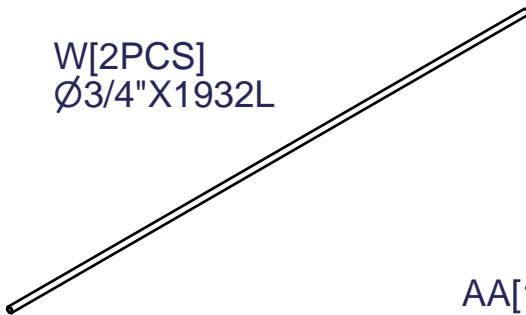

Z[1PCS]
9440-165

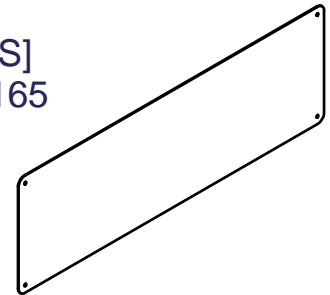

AC[1PCS]
9211-119A

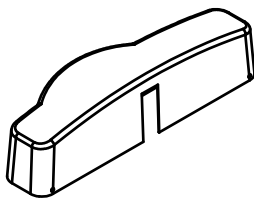

AA[12PCS]
8321-040
both side

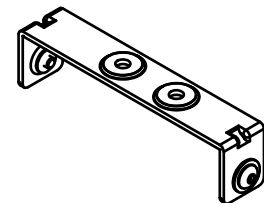
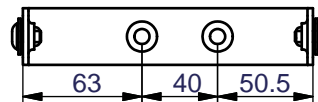

AB[2PCS]
8321-040
one side

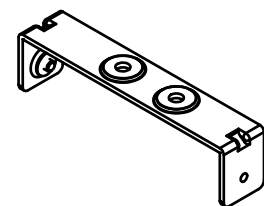
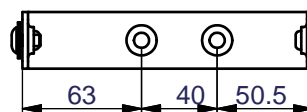

Y[2PCS]
8313-144

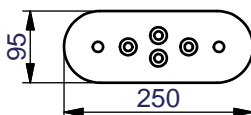

DLAT ASSEMBLY INSTRUCTIONS

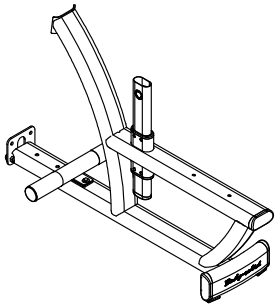

Above shows STEP 1
assembled and completed

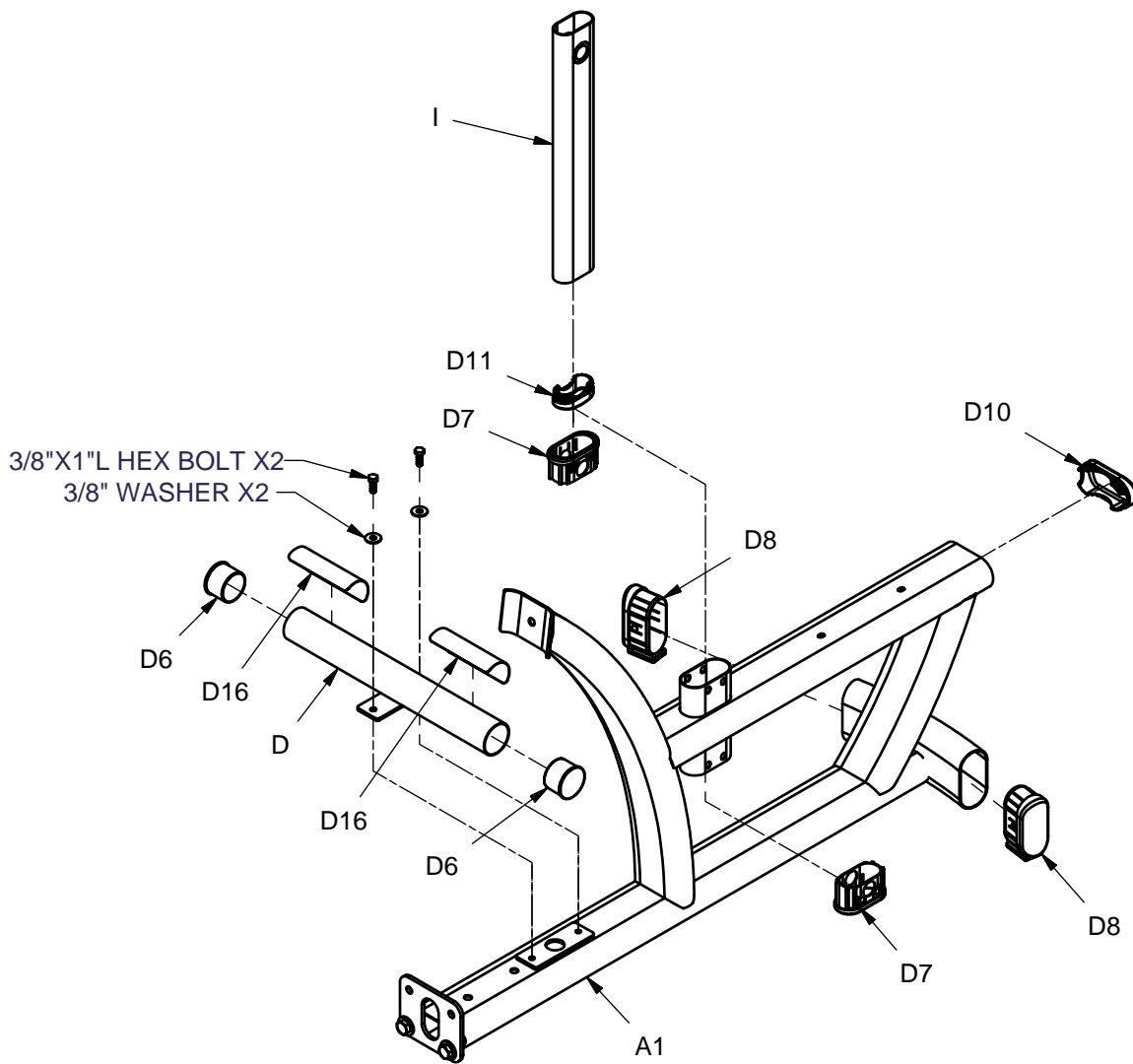

3/8"X1"L HEX BOLT X2
3/8" WASHER X2

DLAT ASSEMBLY INSTRUCTIONS

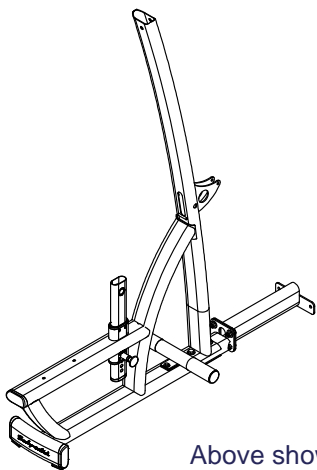

Above shows STEP 2
assembled and completed

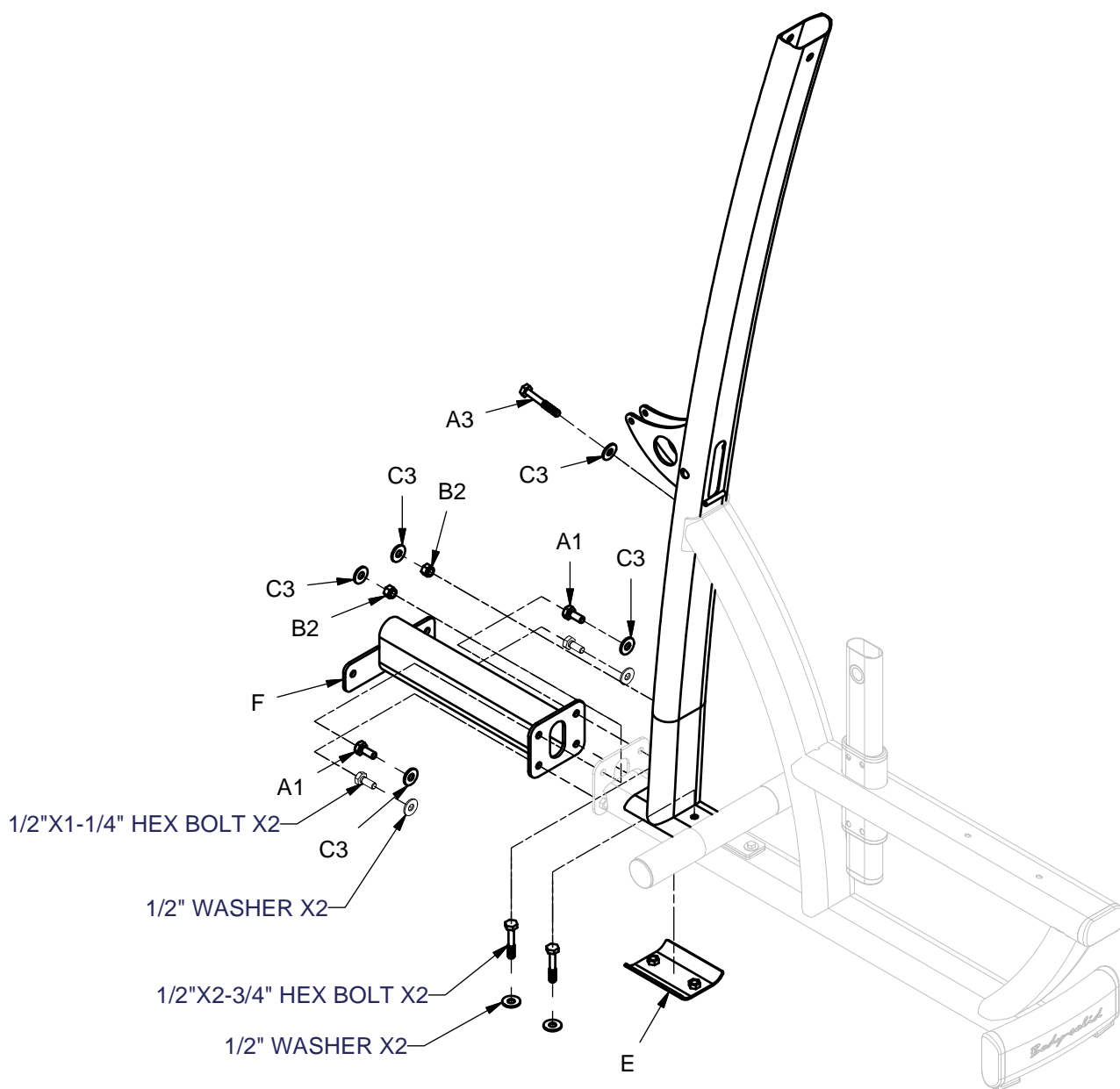

DLAT ASSEMBLY INSTRUCTIONS

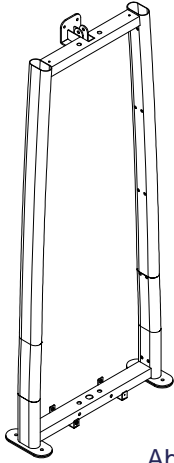

Above shows STEP 3
assembled and completed

DLAT single weight stack assembly instructions

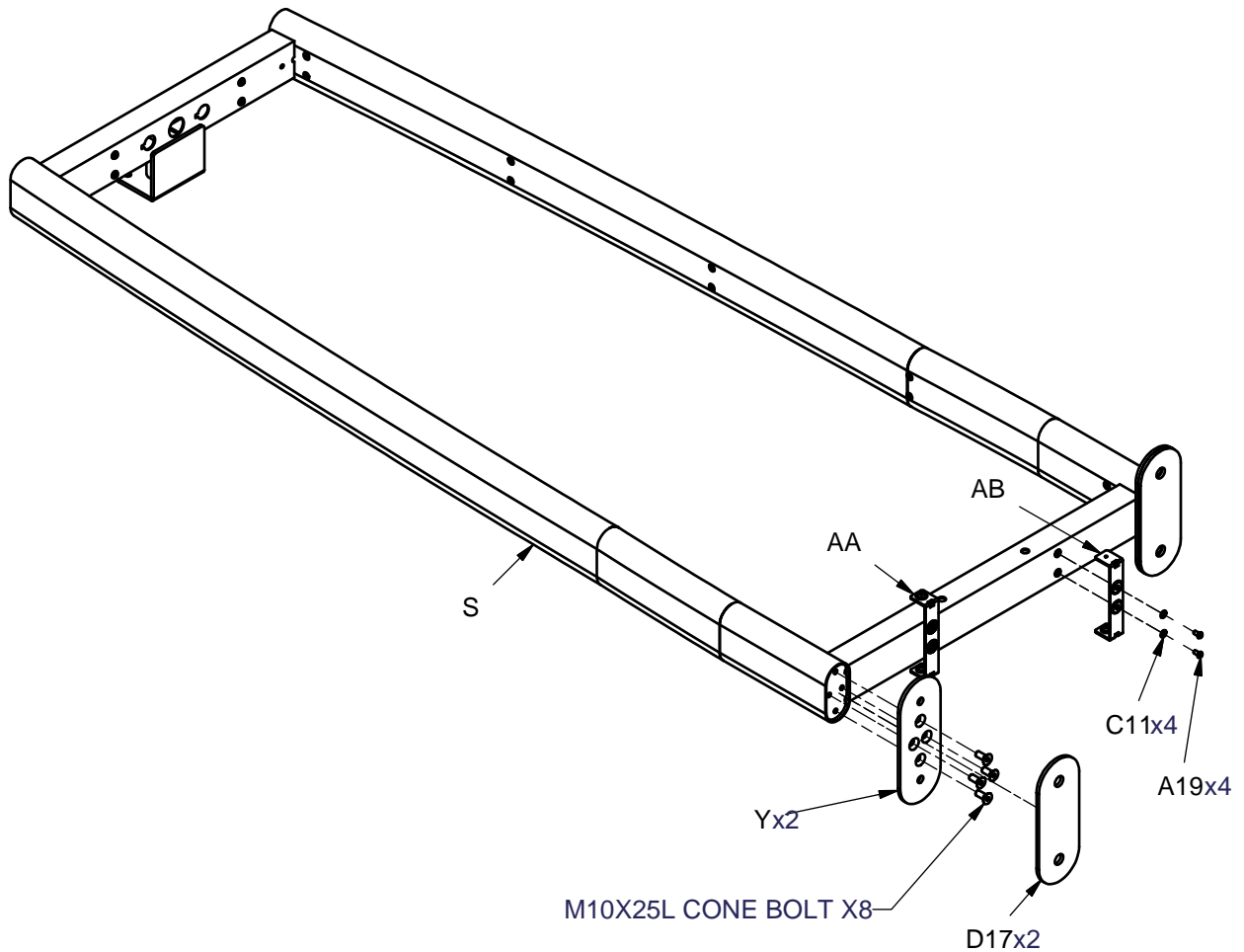

DLAT ASSEMBLY INSTRUCTIONS

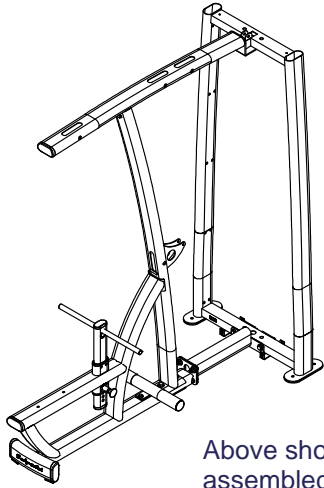

Above shows STEP 4
assembled and completed

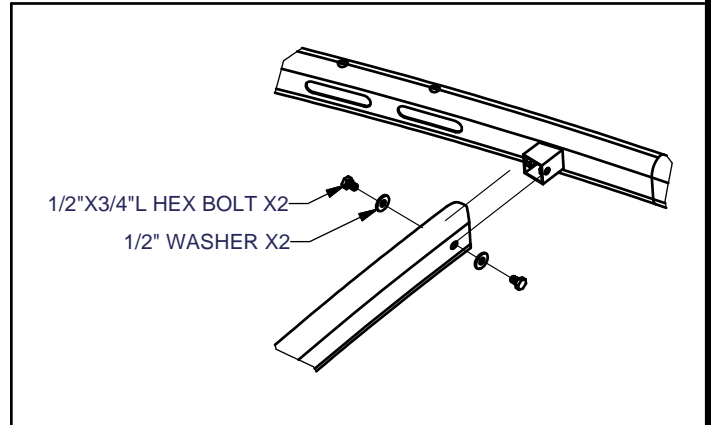

1/2"X3/4"L HEX BOLT X2
1/2" WASHER X2

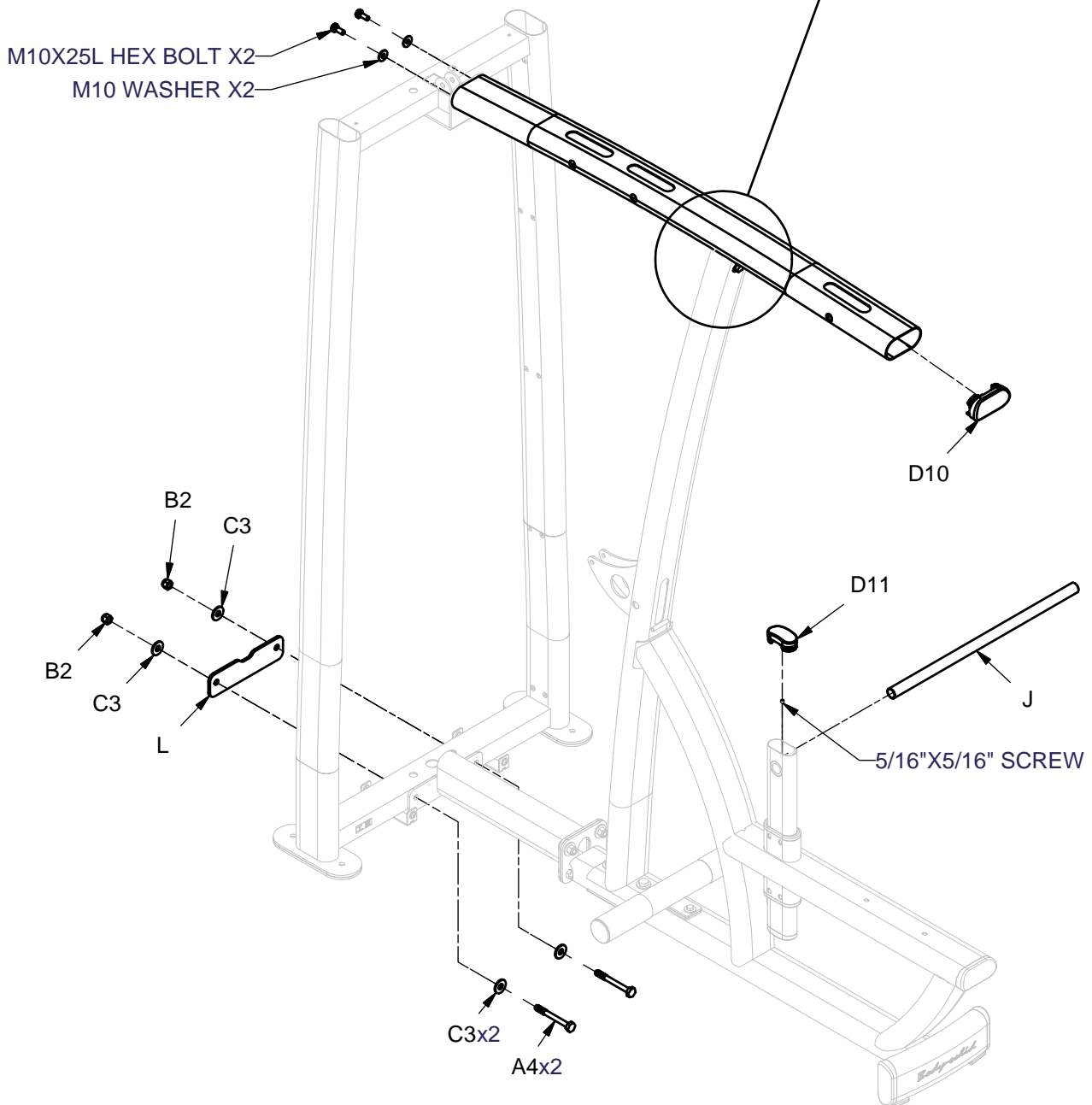

DLAT ASSEMBLY INSTRUCTIONS

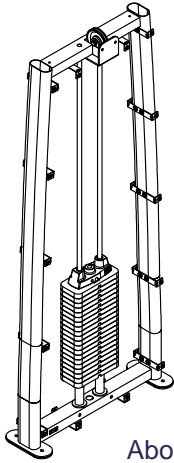

Above shows STEP 5 assembled and completed

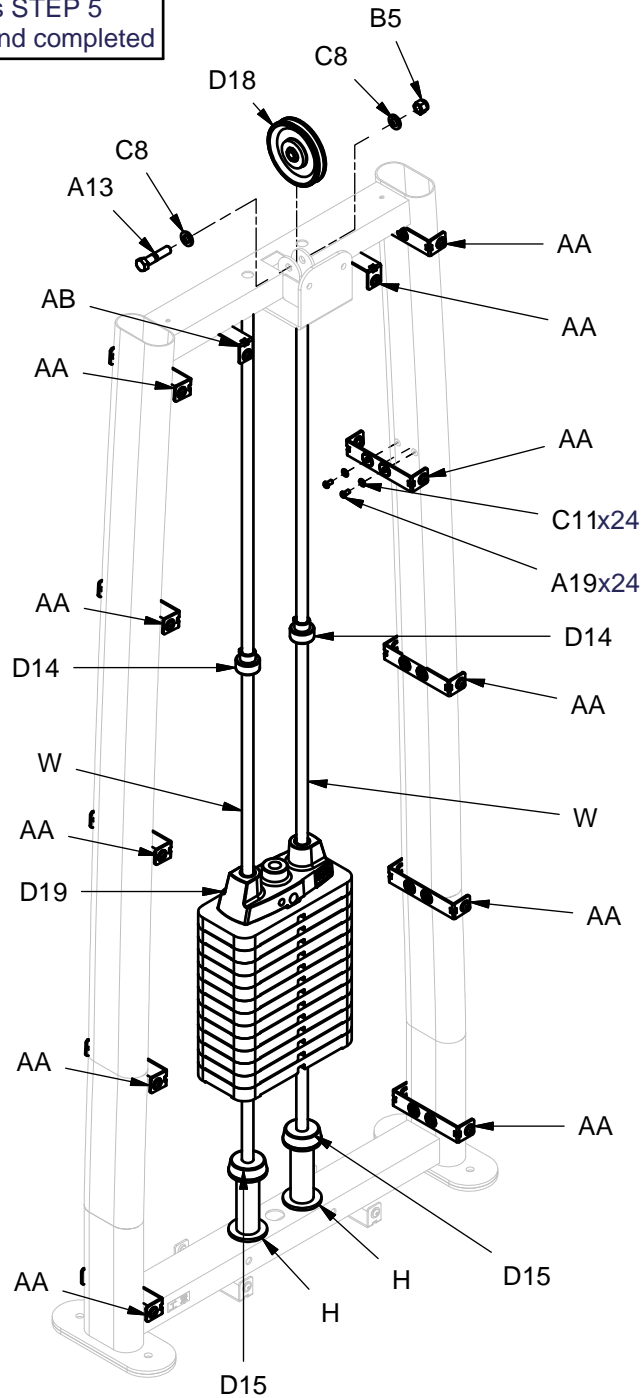

DLAT ASSEMBLY INSTRUCTIONS

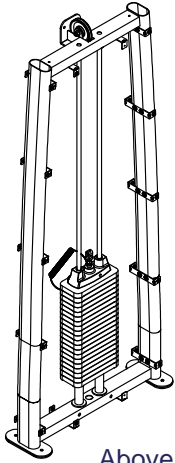

Above shows STEP 6
assembled and completed

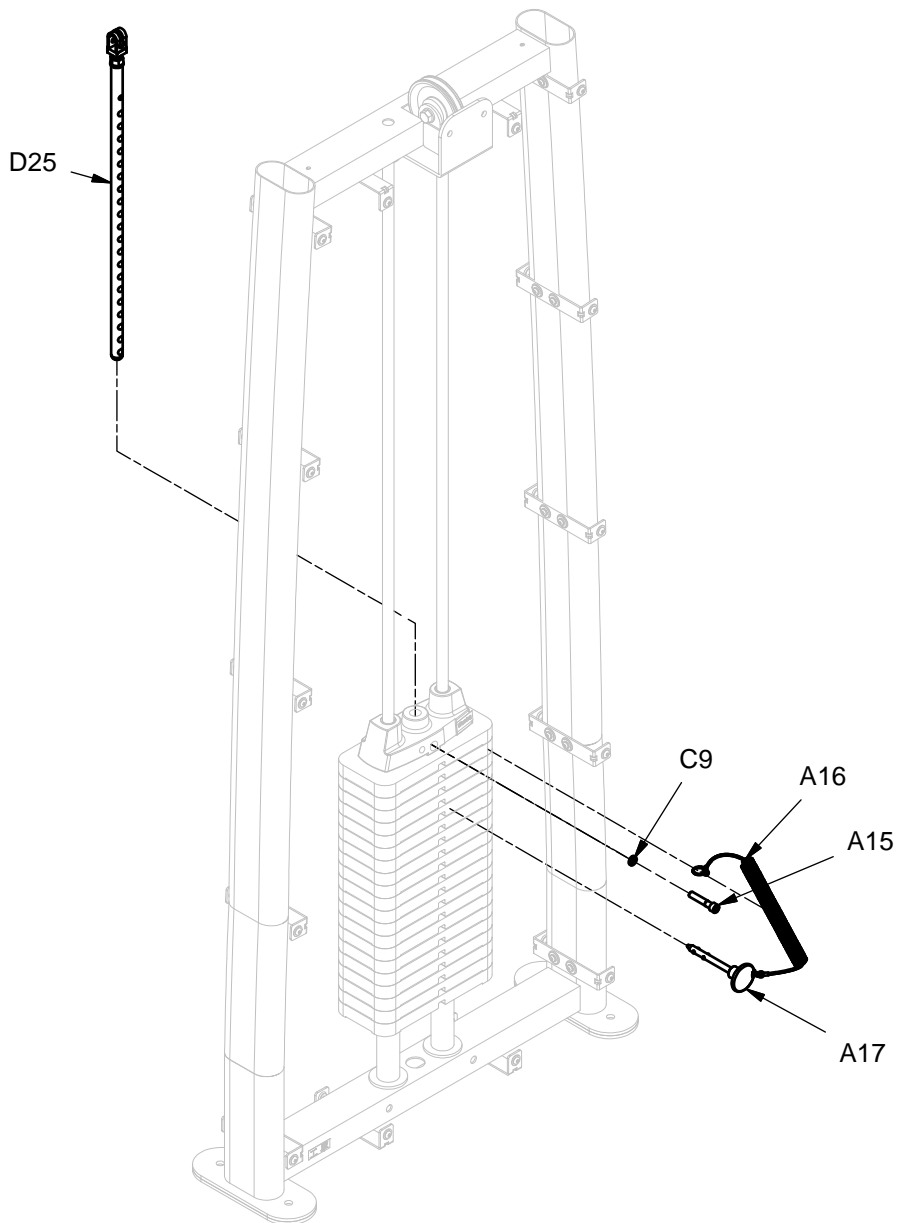

DLAT ASSEMBLY INSTRUCTIONS

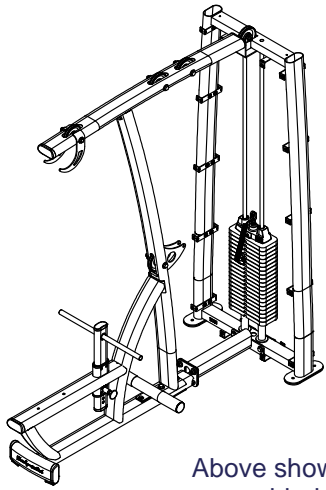

Above shows STEP 7
assembled and completed

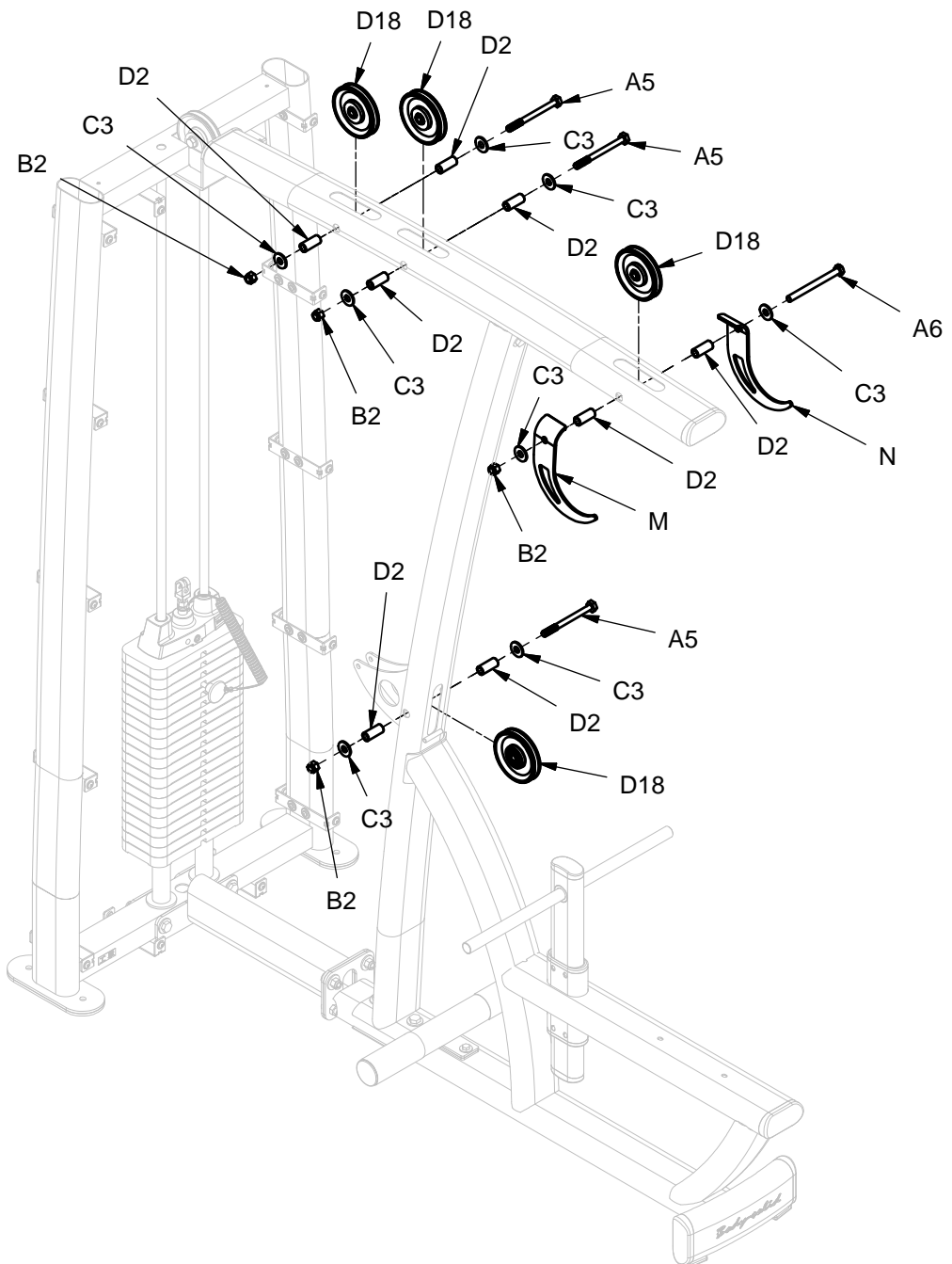

DLAT ASSEMBLY INSTRUCTIONS

Cable to match illustration

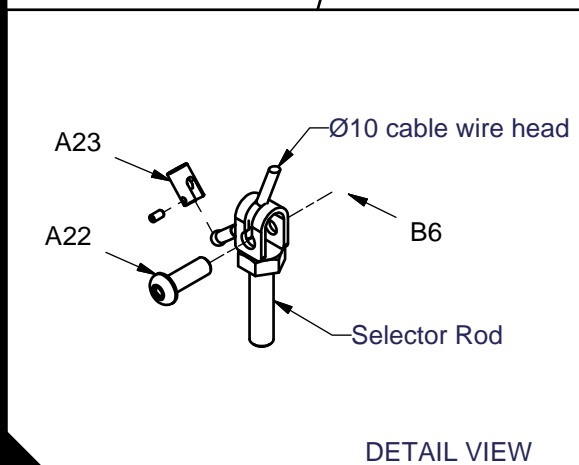
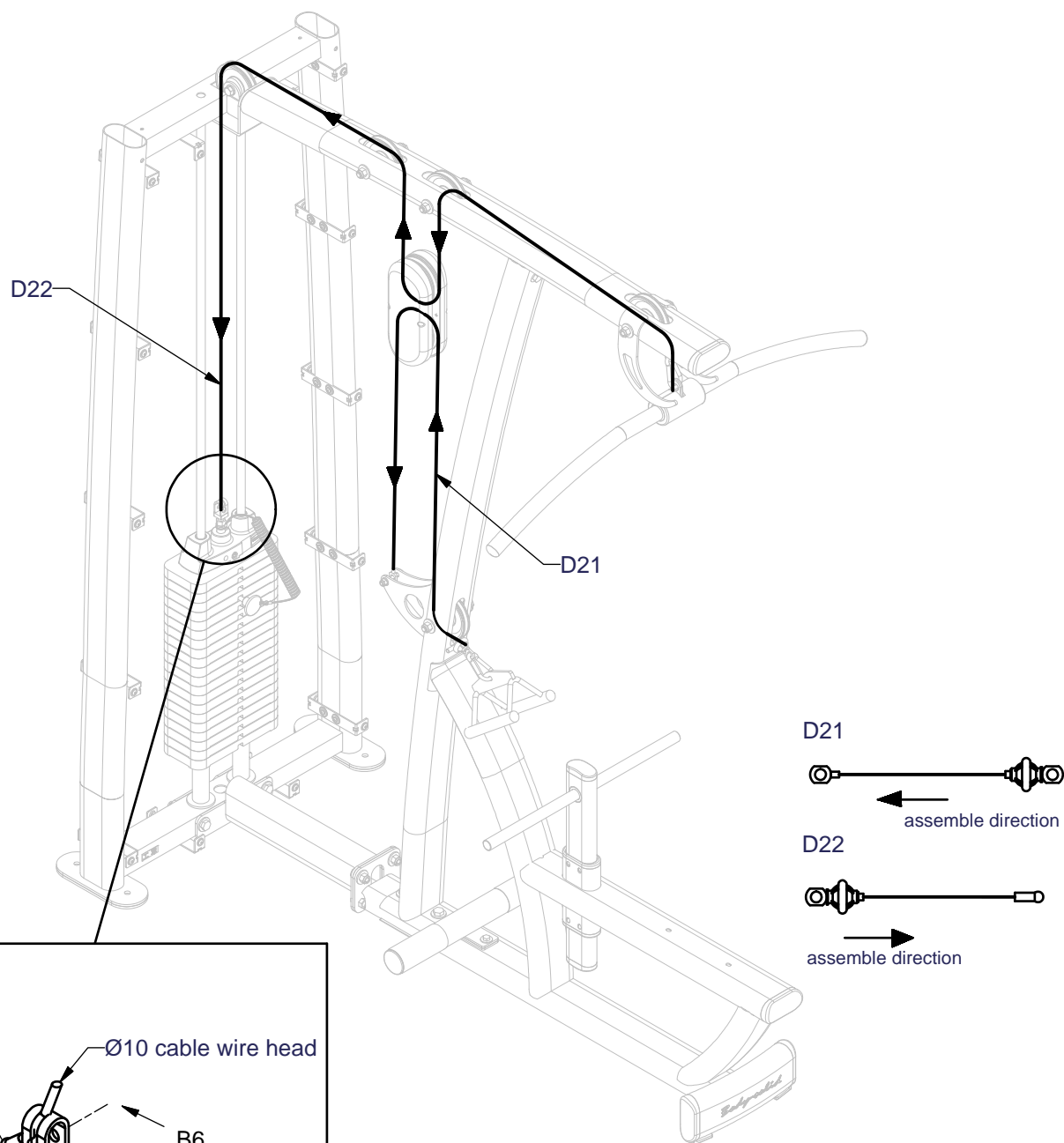

DLAT ASSEMBLY INSTRUCTIONS

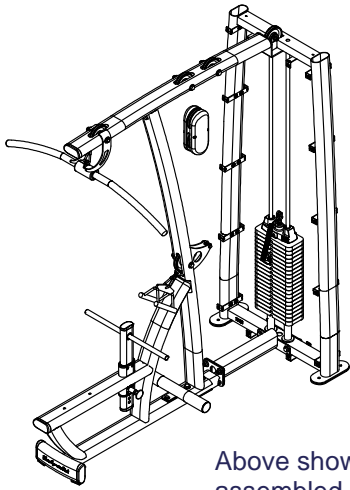

Above shows STEP 8 assembled and completed

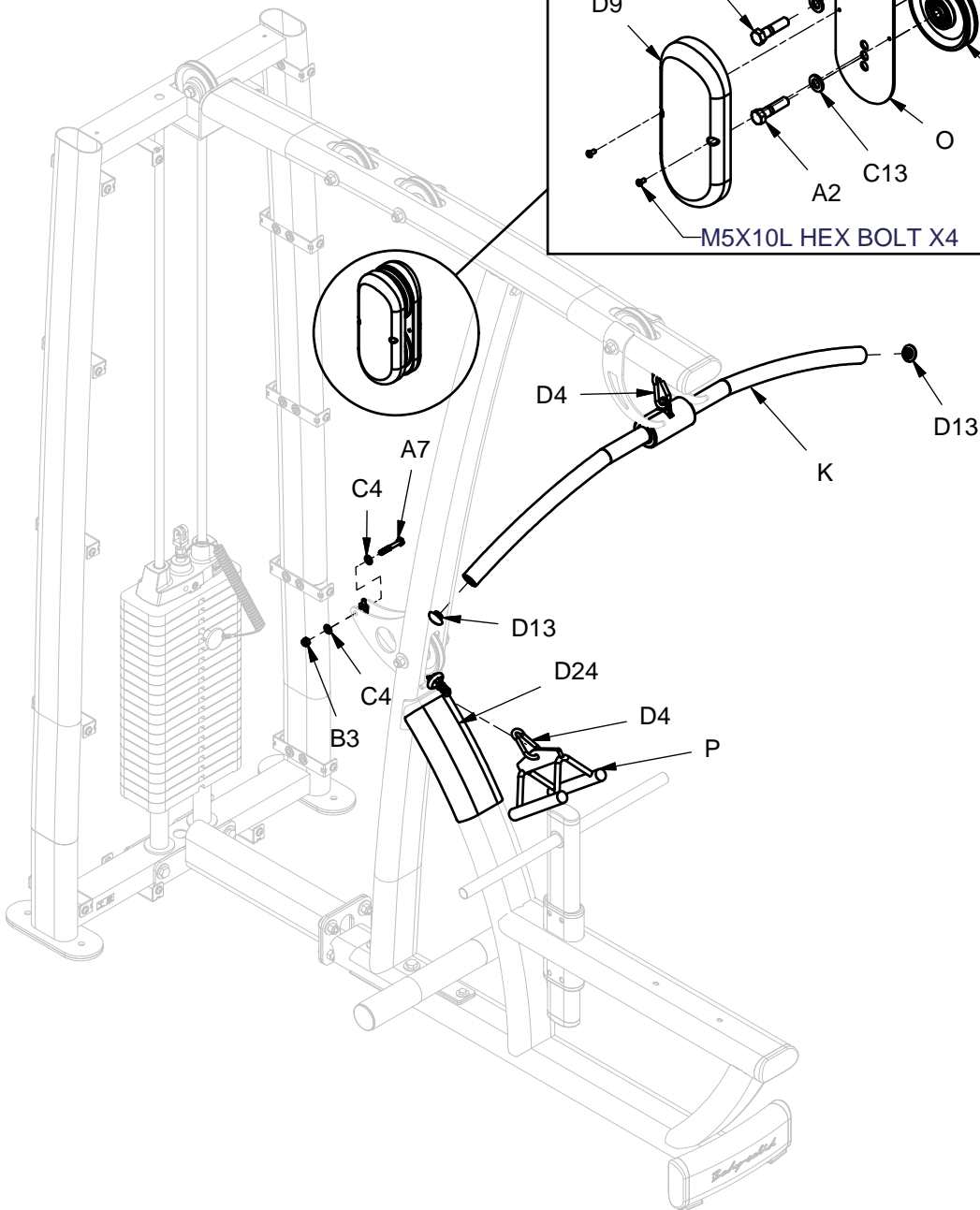
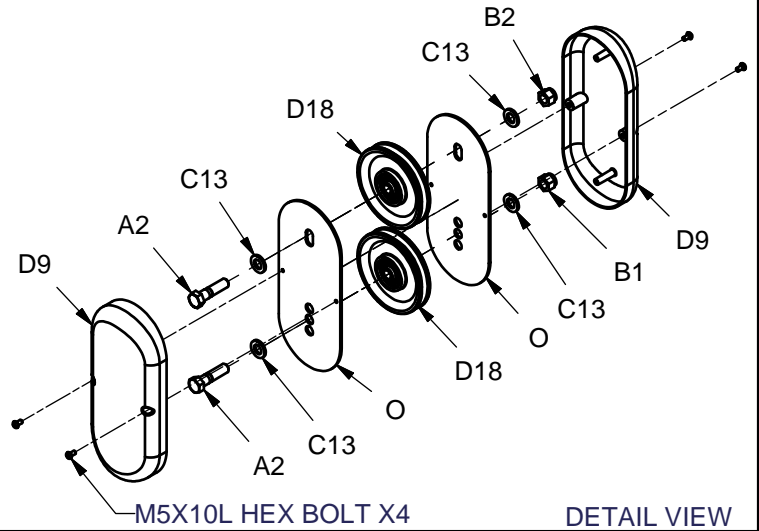

DLAT ASSEMBLY INSTRUCTIONS

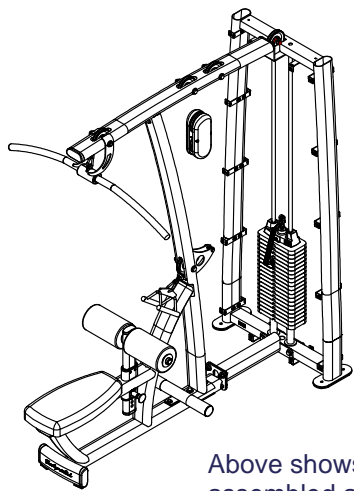

Above shows STEP 9 assembled and completed

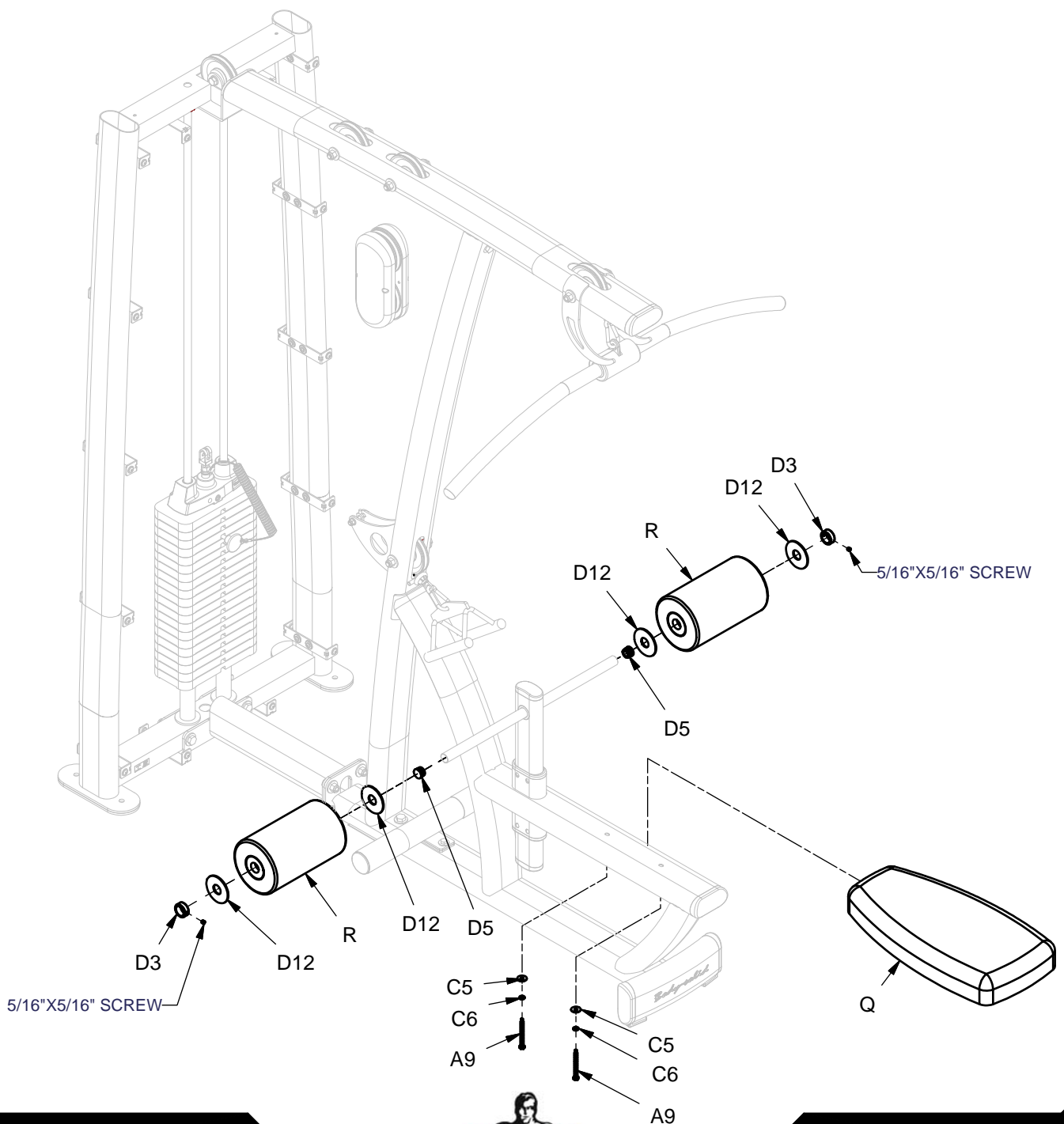

DLAT ASSEMBLY INSTRUCTIONS

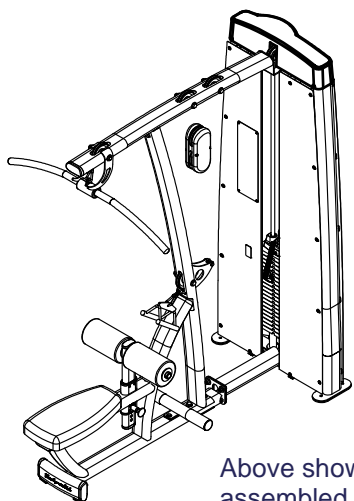

Above shows STEP 10 assembled and completed

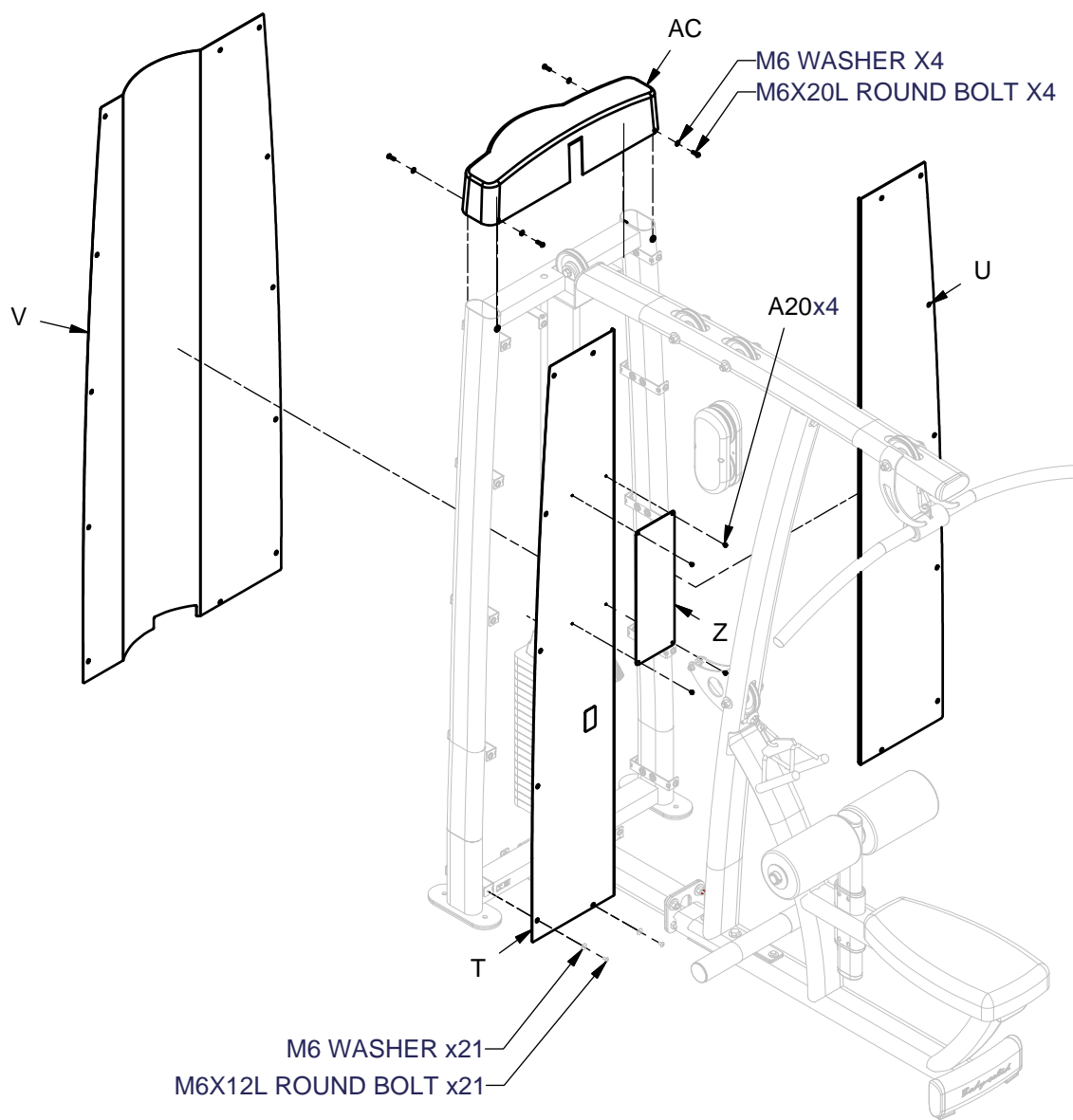

DLAT ASSEMBLY INSTRUCTIONS

Cable to match illustration

D23

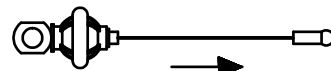

assemble direction

D21

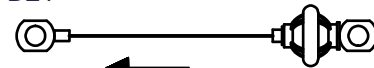

assemble direction

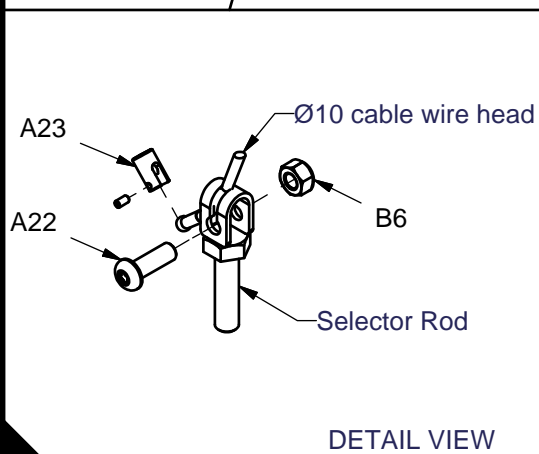
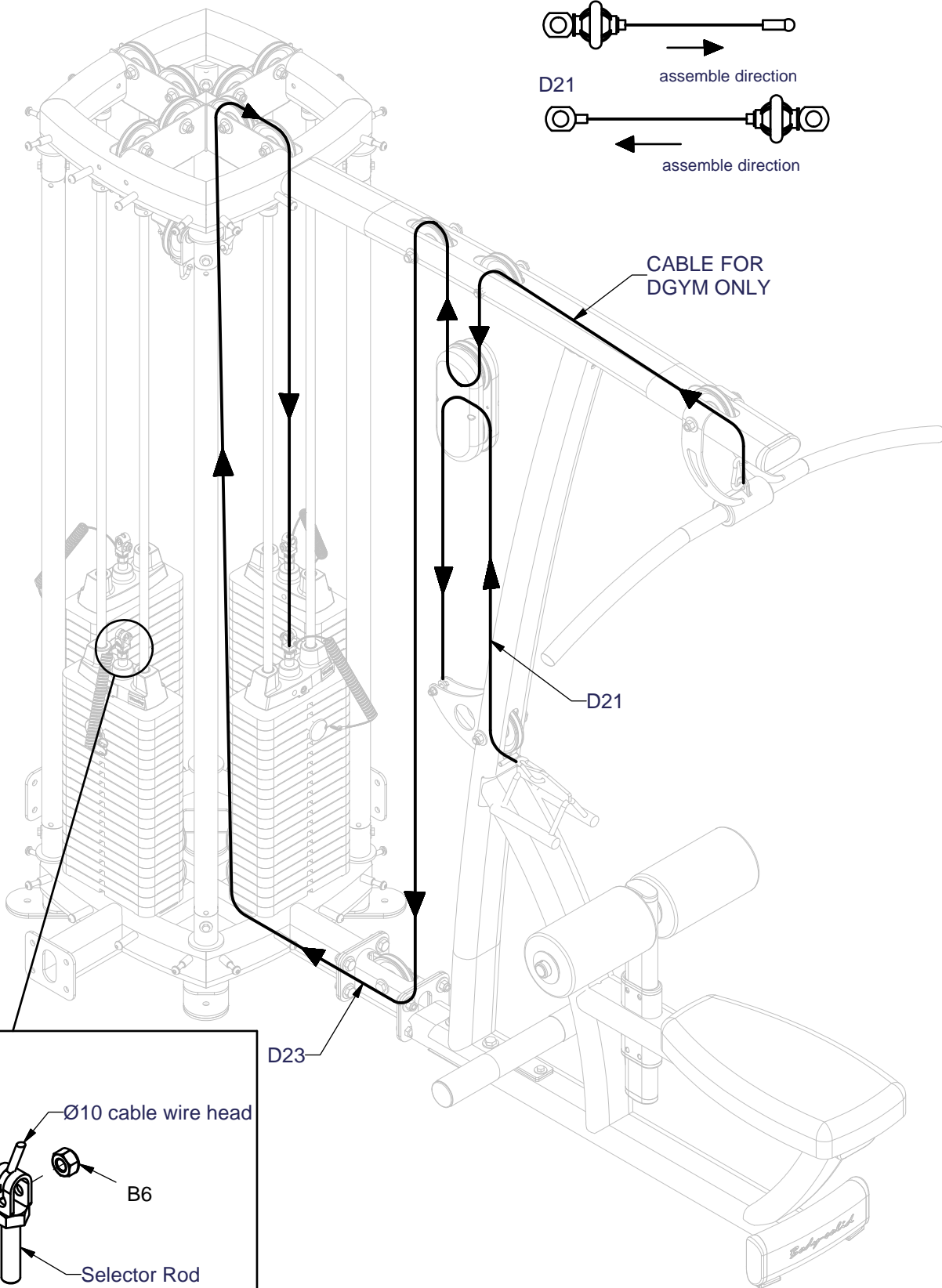

DLAT ASSEMBLY INSTRUCTIONS

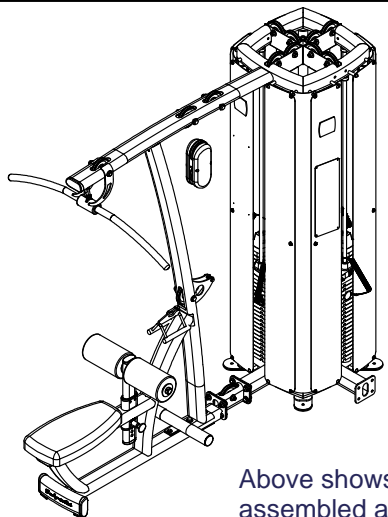

Above shows STEP 11 assembled and completed

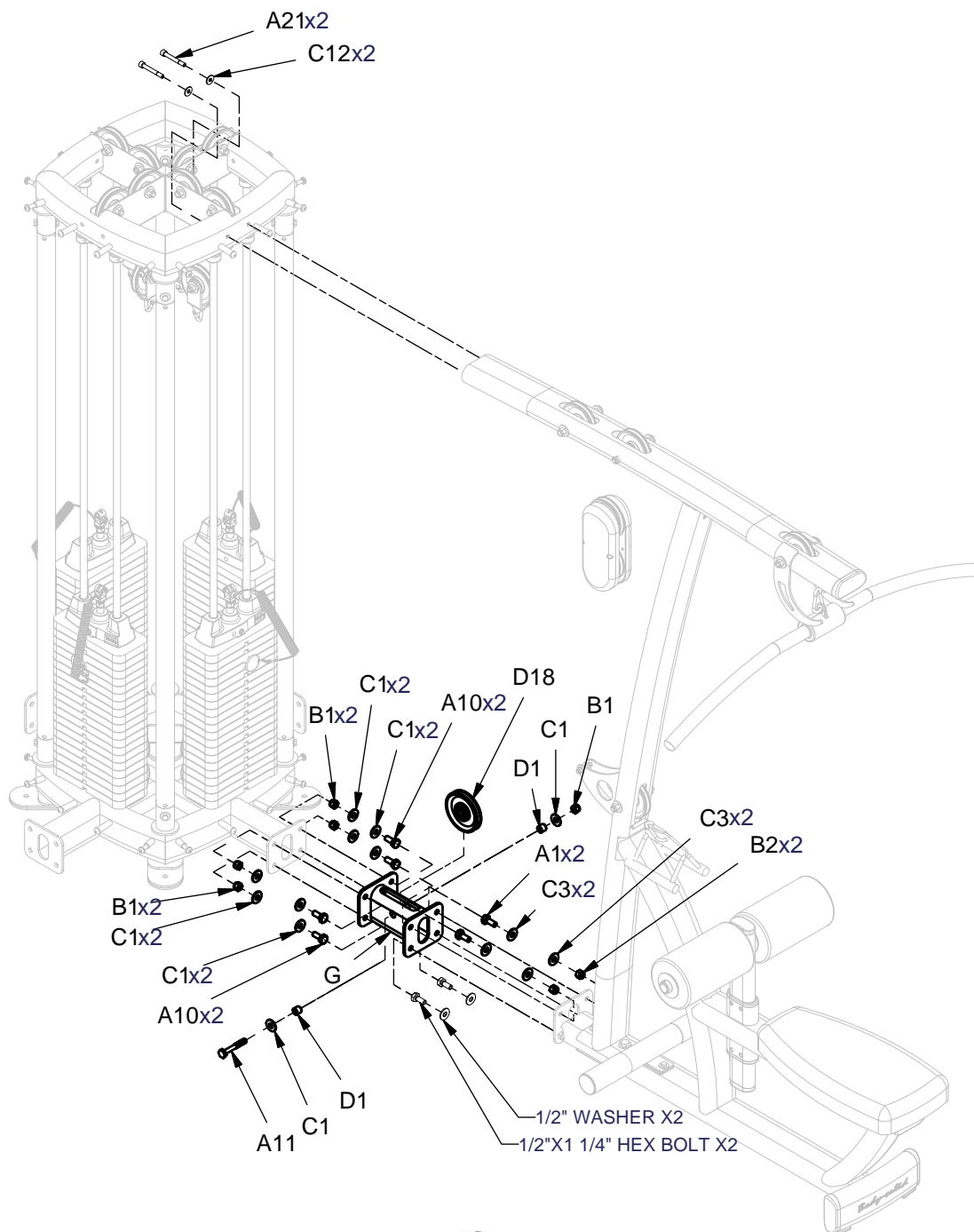

DLAT ASSEMBLY INSTRUCTIONS

